

Operator's manual

Pentruder® 6-8HF HF-wall saw
Pentpak® High frequency power pack

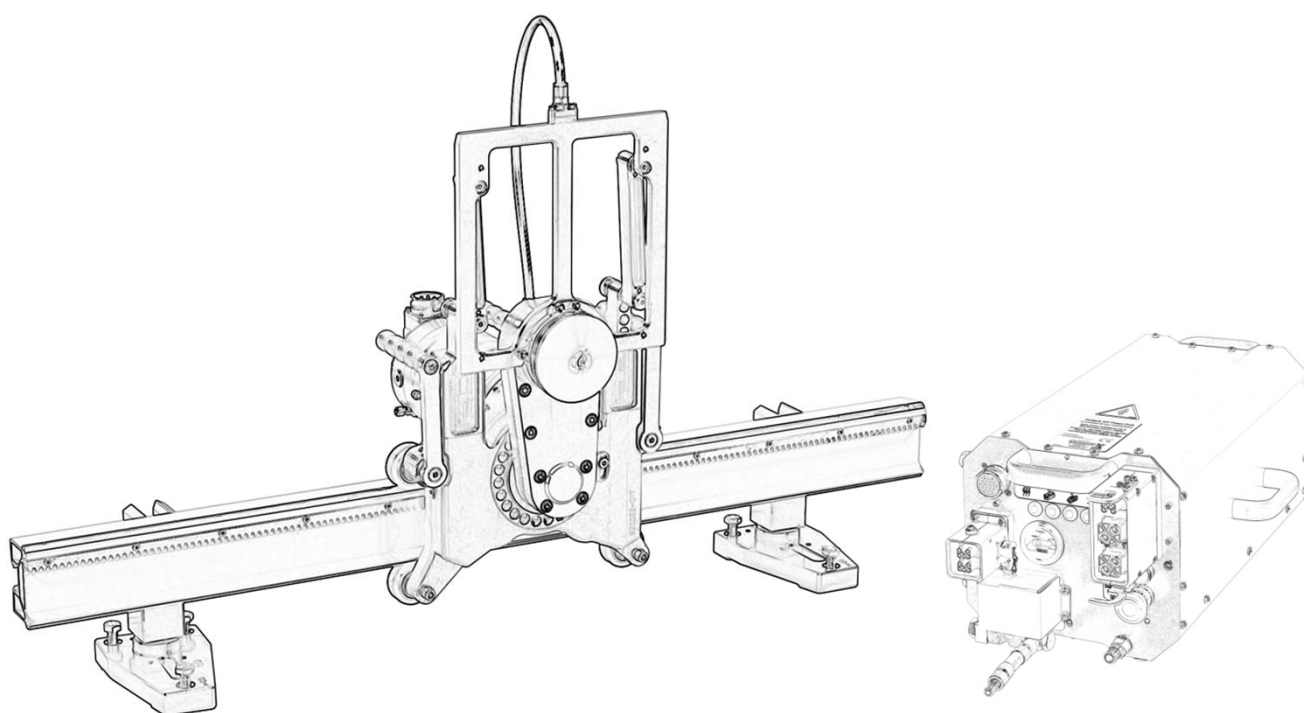

Pentruder®

by TRACTIVE

**Operator's manual for
Pentruder® 6-8HF-wall saw and
Pentpak® high frequency power pack**



**Version: 1.1 Date: 2012-01-03
Support & Service document
Original instructions**



Copyright © 1997-2012 Tractive AB.
Pentruder and Pentpak are registered trademarks belonging to Tractive AB.

Contents

Introduction	2
Description of the machine	3
Saw head Pentruder 6-8HF with accessories	3
Tracks and brackets	4
Blade guard	5
Pentpak high frequency (HF)-power pack	5
Design, function and special features of the Pentpak HF-power pack.....	6
Intended use of the Pentruder 6-8HF and Pentpak	7
Safety precautions	7
Getting started	9
Preparations before commencing work	9
Preparation and mounting of track feet and tracks	10
Mounting the saw head on the track	12
Blade flange	13
How to fit a blade on a standard blade flange:.....	13
How to fit a blade on a flush cutting flange:.....	13
Peripheral cutting speed and spindle speed	15
Mounting the blade guard	16
Preparing the power pack	17
LED type warning lights on the power pack	19
Remote control unit	21
Maintenance	24
Technical Data Pentpak 418 HF Power Pack	27
EC-declaration of conformity	28

Introduction

Thank you very much for your confidence in our product! You have chosen to invest in a product which will give you many years of efficient and profitable production. The Pentruder 6-8HF has been developed based on more than 25 years of experience in this specialised field. With correct handling it offers outstanding performance, safety and reliability.

It is essential that all personnel working with, or in close proximity to, the saw have read and understood the contents of this manual before commencing operations. Only by reading and understanding the manual will the operator be able to take advantage of the many features and benefits of the Pentruder 6-8HF. We are confident that your investment in this equipment and its many design features will enhance your companies' competitive edge and profitability!

The first section of this manual, page, contains the table of contents and an introduction of the machine.

The second section of this manual, page, contains a general description of the machine and explains the different features which make the Pentruder 6-8HF to one of the safest and most efficient machines available on the market today.

The third section of this manual, page, contains a description how to get started with the machine. Please take careful note of the Safety Precautions.

The fourth section of this manual, page, contains instructions how to maintain the equipment, and technical data.

Important! *When you read this manual it is important that you read and understand what is said about safety under the headlines "Important". In those paragraphs beginning with "Important" we inform about risks connected with use of the machine, and, if the safety precautions are not respected, can result in damage to property and persons in close proximity to the machine.*

Warning! *When you read this manual it is important that you read and understand what is said about safety under the headlines "Warning". In those paragraphs beginning with "Warning" we inform about risks connected with use of the machine, and, if the safety precautions are not respected, can result in serious injury and even to fatal injuries to persons in close proximity to the machine,.*

To avoid serious or even fatal injury to the operator and persons in close proximity to the machine, it is important that the machine always is operated by trained, responsible personnel.

Description of the machine

The Pentruder 6-8HF represents a very modern and safe type of concrete wall saw. The Pentruder 6-8HF was developed and manufactured by **Tractive AB** in Sweden in a process where safety awareness, performance and reliability were the most important design parameters.

By taking advantage of experience and know-how built up over many years in this specialised field, this new design can offer the user great advantages, for example the markets best performance to weight ratio.

The Pentruder 6-8HF offers outstanding quality. It is the culmination of exacting goals for quality and safety set at every stage from concept to finished product.

Saw head Pentruder 6-8HF with accessories

The Pentruder 6-8HF is the overall most efficient machine for concrete cutting available on the market today. When the overall efficiency of the system is evaluated, all aspects of the work must be considered. The features of the 6-8HF mentioned below all contribute to make your work safer, easier and more efficient.

- Low weight, only 26.3 kg complete, including blade flange and 15 kW Motor. For efficient cutting with blades from Ø 600 (23.6") to 800 mm (48") diameter.
- Lightweight saw head built from aircraft quality components machined from solid aluminium. No castings are used. For optimum accessibility the saw arm can be rotated through 360 degrees in either direction.
- The saw head accepts an 750 mm (30") saw blade free from the wall.
- Double motor cooling system, i.e. both rotor and stator are cooled, for sustained reliable power and high efficiency.
- Efficient water supply to blade central through blade flange, even for flush cutting blades.



Warning! The guard must be fitted whenever the machine is run.

Tracks and brackets

The tracks and the brackets are designed to provide high levels of rigidity and stability for the lowest possible weight. The design is unique in the sense that it allows the guide rollers on the saw head to be aligned above each other, in the same plane as for the cut. This is to provide the highest levels of safety, stability and precision of cut.



- The tracks are very lightweight at only 4.3 kg / m track. The stiffness and stability in the system is still, in spite of the low weight, sufficient for heavy loads and jobs where up to 1.2 m (48") diameter blades are used.
- The tracks have steel guide rails on which the rollers run. They offer high wear resistance and precise guidance of the saw head. The grooves into which the guide rails are located have been machined with great precision.
- The tracks are quickly and easily mounted in an easily accessible yoke by means of a T-slot piece, which in turn is provided with a lubricated and protected screw and case hardened sleeve-type nut. The hardened sleeve-type nut safeguards that the screw preload is always adequate to clamp the track. This system improves safety and reduces the possibility of the nut working loose because of vibration or variations in load.
- The brackets are versatile and easy. A minimum of two brackets are needed to fit one track. When two tracks are joined, at least three brackets must be used, one of which must be mounted directly over the joint between the two tracks.

Blade guard

The blade guards are made from sheet metal of hardened aluminium, screwed together with spacers to achieve strength and stiffness. For the 6-8HF the blade guard holder is fixed on the saw head. The Pentrunder 6-8HF only uses the fully covering, "parallel blade guards".

The blade guards are available in two different sizes, Ø 600 (23.6") and Ø 800 (32") for normal and flush cutting.

- Automatic control of the blade guard through the movement of the saw arm, the operator need not adjust the guard manually while the machine is in operation.
- Detachable side pieces. The guards are divided in three pieces with a fixed centre piece and two detachable side pieces for cutting into adjacent surfaces.



Pentpak high frequency (HF)-power pack

The Pentpak high frequency (HF-)power pack is designed to a new and unique concept. The electronic units are especially designed for the Pentpak and the power pack is one of the most compact designs on the market. It offers outstanding performance combined with reliability, safety and ease of handling.

Depending on voltage and chosen HF-motor there are different HF-power packs.

For 380 – 480 V Input voltage there is the Pentpak 427 for up to 27 kW HF-motor, Pentpak 422 for up to 22 kW HF-motor (this power pack is no longer sold) and Pentpak 418 for up to 18 kW HF-motor. For 200 – 230 V Input voltage there is the Pentpak 200 for up to 22 kW HF-motor (400 Hz input frequency), the Pentpak 218 for up to 18 kW HF-motor and the Pentpak 222 for up to 22 kW HF-motor. In the following operator's manual Pentpak HF-power pack or just Pentpak is used to refer to all of the Pentpak HF-power packs listed above.

New regulations for the design of machines and the specifications for their inherent safety have been the ruling parameters in the design and development of this power pack.

Design, function and special features of the Pentpak HF-power pack

- For optimum safety and manoeuvrability all functions are controlled through a remote control unit. The operator can therefore always be in the safest and best possible position and still have full control of the machine.
- The remote control system contributes to a high level of safety. All functions are reset automatically when the power supply is disconnected, or when any of the Emergency Stop-buttons are depressed. The blade, if in rotation, and in a cut, will continue to rotate because of its inertia, but will coast to a stop after a few seconds. If the blade is rotating and not in a cut, it will take longer before the blade stops. No functions remain after the power pack has been shut off. At every restart the power pack starts from the same initial mode with all functions reset.
- The converter is water cooled which provides excellent cooling of the transistor power modules in the frequency inverter.
- If the power pack is run using an inadequate supply of cooling water, it is still protected from overheating by means of a temperature sensing device inside the power pack.
- The Pentpak HF-power pack is compact and weighs only 26 kg, still it can drive an electric motor with a continuous output of up to 27 kW depending on model.
- The power pack has a high overall efficiency factor and at 400 V a 32 Amp delay fuse will be enough to run the power pack and motor at their maximum rated output. We recommend to use a 40 Amp fuse if possible. Even 16 Amp (25 Amp for the 27 kW HF-motor) delay fuses can be used but then the power output must be reduced by turning the feed rate knob on the remote control.
- All electrical and electronic equipment is protected under covers and cannot easily be tampered with. The only device that can be operated is the (green) start and emergency stop buttons.

Intended use of the Pentruder 6-8HF and Pentpak

Pentruder 6-8HF is intended to be used together with a Pentpak HF-power pack and may only be used for cutting of concrete and similar materials. It is our expressed recommendation that the machine **not** be used for cutting in any other materials. The Pentruder 6-8HF saw head cannot be used with other types of power packs. If connected to other types of power packs (frequency inverters) Tractive AB disclaims any responsibility for the product.

Warning! Please observe that Tractive's responsibility as a manufacturer can only be accepted when the saw head, Pentruder 6-8HF, is used together with power packs, machines and accessory equipment of Tractive's manufacture and origin. If the Pentruder saw head is used with non-original equipment the warranty will be void.

The Pentpak is primarily intended to power Pentruder HF-wall saws. It is also used for powering other machines of our manufacture, like the MD1, 4-speed drill gearbox, as well as our wire saws. Please contact your distributor for information. Please observe that Tractive's responsibility as a manufacturer only can be accepted when the Pentpak is used together with machines and accessory equipment of Tractive's manufacture and origin.

Important! Always consult Tractive AB or our representative before any other type of machine or equipment than the Pentruder 6-8HF is connected to the power pack. Observe that Tractive's responsibility as a manufacturer can only be accepted when the saw head Pentruder 6-8HF is used together with power packs, machines and accessory equipment of Tractive's manufacture and origin. If the Pentruder saw head is used with non-original equipment the warranty will be void.

Safety precautions

It is of paramount importance that the operator has full knowledge and understanding of the instructions below:

This wall saw may not be used unless the operator is fully familiar with the contents of this manual and has been trained in its operation by an authorised distributor of Tractive AB's products. The operative is fully responsible for the manner in which the machine is operated. It is the responsibility of the purchaser that the operator has received the information needed to operate and handle the machine in a safe and correct way.

Warning! Faulty handling of the machine can expose the operator and / or persons in close proximity to the machine to extreme danger.

Tractive AB disclaims all responsibility for damages to persons and / or property resulting from use of the machine, whether they are caused by faulty handling or from damages that have occurred as a consequence of negligent or faulty maintenance, or as a consequence of failure to check and control the machine with regard to damages and / or faults.

Warning! A Pentruder wall saw used in the correct way is a safe and efficient tool. If the machine is used improperly this can expose the operator and other persons staying in the same area to extreme danger or even risk of fatal injuries.

Warning! Basic safety precautions are that all persons present in the same area or in the same place as the machine shall wear protective equipment including helmet, safety shoes, gloves, eye and ear protection, and that all other safety precautions applicable on site are to be

respected. Track stops must always be securely mounted at each end of the track(s) to prevent the saw head from being run off the track unintentionally.

Warning! A saw blade rotates at up to 60 m/s peripheral speed, i.e. over 200 km/hour (120 mph). The energy stored in such a blade is considerable, and it is always important that the machine always is mounted according to the instructions given in this manual, and that the blade guard **always** is fitted.

Warning! Always check that the equipment is in faultless condition and that all functions are in order before work is commenced.

Warning! Never connect the power cord from power pack to the HF motor while the power pack is switched on. Press at least one of the Emergency Stop buttons before the power cord is connected to power pack and HF motor.

Warning! The power pack must always be switched off and the 32 Amp plug and cable disconnected from the power pack before any kind of service or repair is commenced.

Warning! Mounting and dismounting of the saw head may only take place when the saw head is disconnected from the power pack by removing the power cord from the saw HF motor and the 24V DC cord to the feed and travel motors.

Warning! Mounting and dismounting of the **blade guard and saw blade** may only take place when the saw head is disconnected from the power pack by removing the power cord from the saw HF motor and the 24V DC cord to the feed and travel motors.

Warning! Track brackets may only be mounted according to the instructions given in this manual.

Warning! To maintain the level of safety inherent in the design of this machine, only Tractive original spare parts may be fitted. Tractive AB disclaims all responsibility for any damage occurring as a result of use of non original parts.

Important! The power pack should preferably only be operated when it is put on its back with the hour meter pointing upwards.

Important! The power pack is water cooled and must be drained from water when the ambient temperature is in the proximity of or below 0 degrees Celsius. **The Pentpak has an electrically operated water ON/OFF valve. To drain the power pack completely in sub zero temperatures, switch off the blade motor, disconnect water supply, switch on water on the remote and blow out all water in the Pentpak 418 Power Pack, hoses and saw head HF-motor with compressed air.**

Important! The power modules in the power pack are water cooled and the water pressure must therefore be limited to max 5 bar. The incoming water supply may only be connected to the short hose on the water ON/OFF valve on the power pack. The quick disconnect couplings may not be replaced with couplings that are not fully open when disconnected.

Important! Connect the power pack only to Pentrunder 6-8 HF or such equipment which has been manufactured or approved by Tractive AB.

Getting started

Preparations before commencing work.

Certain preparations must be done before starting work.

Cleaning: The machine should be carefully cleaned and all functions checked and are found normal before use of the machine.

Tools: Use only those tools that are intended to be used to operate the machine:
Ratchet 1/2" Kamasa, Socket 1/2" - 19 mm, Allen socket 1/2" 8mm x 90 and T-key 8mm x 100.



Guide rollers: Check that the guide rollers on the saw head can move freely without too much friction. A certain amount of friction is always present as the bearings are double sealed with both rubber and steel scraper seals. Replace bearings and shields when worn or if rollers don't run freely.

Remote Control unit: Check the remote control unit for correct function and that the Cannon connector is clean and undamaged.

Water feed: Check that the machine can be supplied with clean cold water, minimum 4 L / minute (1 GPM).

Power cords: Check that all cords are undamaged and in faultless condition.

Power supply: Check if sufficient power is available on the site. The machine must be connected to a 380 – 480 V 3-phase supply with minimum 16 Amp fuses. Preferably a 25 Amp fuse is used at 400V and 20 Amp @ 480 V for maximum reliability.

Safety precautions on the site:

Check with the foreman responsible that all necessary precautions have been performed before commencing work. Await the approval of the safety precautions and mounting position of the machine from a responsible person before work is commenced.

Warning! *If there is a possibility that cut concrete blocks may fall causing injury or damage to persons or property then they must be secured before starting work. The risk area must be roped off and a responsible person left in charge, in a safe place, to prevent entry of unauthorised persons.*

Preparation and mounting of track feet and tracks

Bolts for fastening: The track feet and the tracks should be mounted in such a way that they can not become detached when the machine is working, or at sudden changes in load on the anchor bolts.

The track feet are designed to fit the track to the surface the machine will work on. The feet must be fixed by means of M12 x 50 (1/2" x 2") screws of 10.9 quality, or better, using a thick washer and anchors of type HKD M12 (1/2") or equivalent.

Warning! *If HKD anchors or other high quality expansion anchors can not be fixed securely, the track feet must be securely fixed with through bolts and large washers to achieve the required level of safety.*

Positioning of feet: The track feet should preferably be mounted in the position shown in the picture above. The distance from the edge of the feet to centre of cut is then 128 mm (5"). The distance from anchor bolt to centre of cut is 217 +- 25 mm (8.54 +- 1").

Alternative position of track feet:

In certain circumstances it is impossible to mount the track feet as shown in the picture below. If the track feet must be mounted differently, this may affect the stability of the track. If this is the case, more track feet should be fitted to spread the load and increase stability.

Adjusting the height of the track feet.

The height of the fork can be adjusted totally 12 mm by turning the fork CW or CCW, to compensate for irregularities on the wall. Please be sure that the fork is not threaded all the way out before the track is mounted. Leave at least $\frac{1}{2}$ a turn from the fully out or in position.

Mounting the track:

The track is mounted using clamp screws which fit into the fork of the track foot. At least two feet must be used to mount one track.

The clamp screws are fitted in T-slot clamps running in T-slots at the rear of the tracks. These T-slot clamps can be locked in any position by means of a knurled knob.

A clamp screw is fitted in to the fork and should be tightened to 50 Nm (fairly hard) with a 19 mm (3/4") spanner.

Warning! Be careful to position the clamp screw in the countersink of the yoke on the

Joining two or more tracks together:

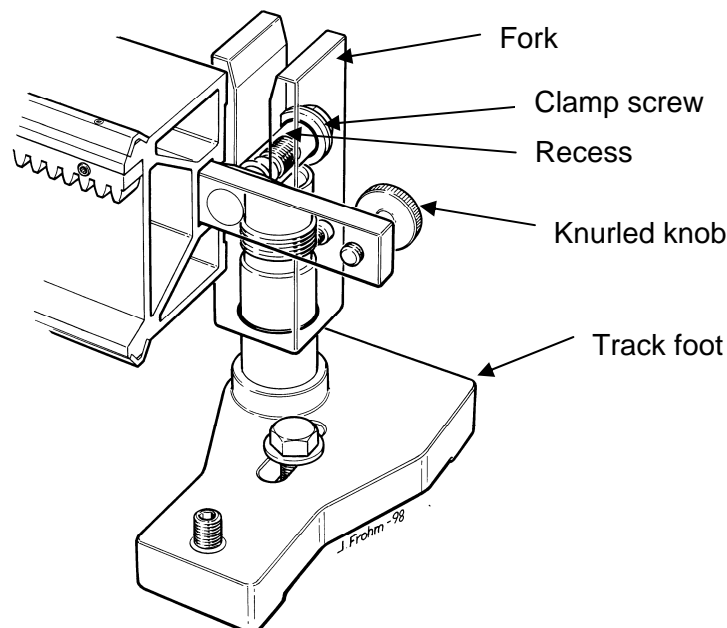

If tracks are to be joined when making long cuts the yoke of the mounting foot should be positioned centrally under the joint. True up the tracks carefully sideways using a spirit level or a straightedge. The alignment in / out relative to the wall is not very critical.

Mounting the saw head on the track

The saw head runs on the track on four conical rollers. The upper rollers are fitted on eccentric shafts, opened and locked by turning the handles. Fold the saw onto the track, the lower "eccentric" rollers engaged first. Move the saw head slightly along the track to engage the travel gear with the rack, then fold the saw completely on to the track, press the locking pins and turn the handles until the locking buttons pops up again.

Warning! Before the saw is operated, always check that the eccentrics are locked in position to prevent the saw from falling off the track. Do not turn the handles unless the locking buttons are depressed.

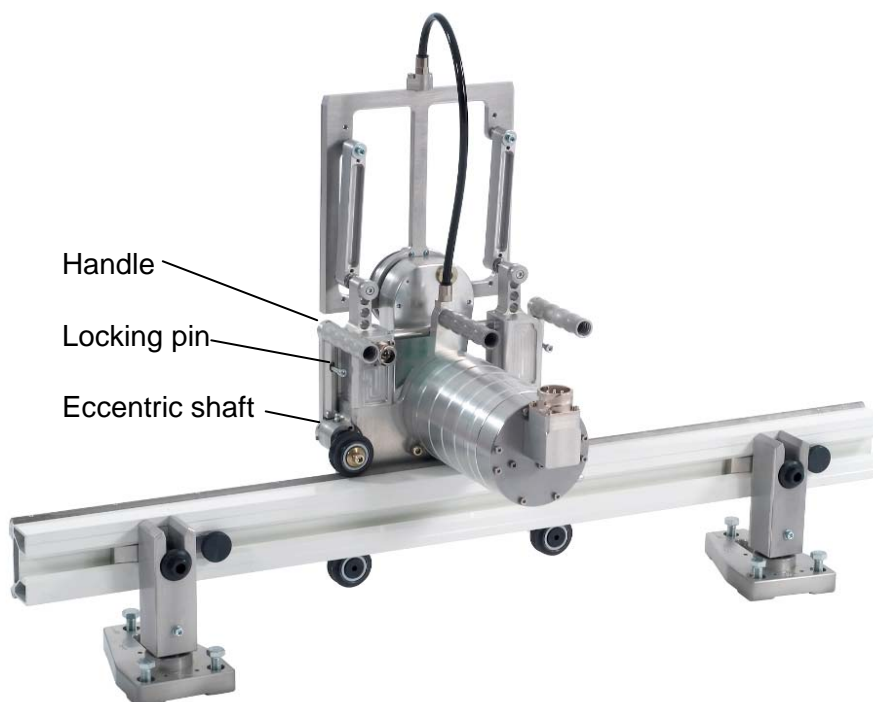

Blade flange

How to fit a blade on a standard blade flange:

Centre bore: The saw blade should have a hole with diameter 60 mm $-0 +0.1$ mm, and be free from cracks, dents, burrs and dirt.

Transmission of torque: An inner flange is fixed on the wall saw at all times. The friction surfaces of both the flange and the blade must be free from grease and dirt to be able to securely transmit the torque of the saw blade motor without slippage. Slippage will cause irreparable damage to the flanges.

Clamping: The blade is fitted on the inner flange and is clamped by the outer blade flange with a special centre screw. The centre screw should be tightened to 30 - 40 Nm.

Warning! *The saw blade must always be fitted correctly to avoid danger. The instructions given above must always be followed to avoid faulty mounting of the blade.*

How to fit a blade on a flush cutting flange:

Centre bore: The saw blade should have a hole with diameter 60 mm $-0 +0.1$ mm, and be free from cracks, dents, burrs and dirt.

Transmission of torque: An inner flange is fixed on the wall saw at all times. The friction surfaces of both the flange and the blade must be free from grease and dirt to be able to securely transmit the torque of the saw blade motor without slippage. Slippage will cause irreparable damage to the flanges.

Clamping: First the blade is fitted on a flush cutting adapter flange with 6 countersunk M8 screws. The bolt circle is 90 mm. Then the flush cutting adapter flange is fitted together with the blade on the inner flange and fixed with the centre screw. The 6 countersunk M8 screws should be 30 mm long and will pass through the nut and into the fixed, inner blade

The Pentrunder 6-8 HF is a powerful machine. This means the blades which are fitted for flush cutting must be properly fixed to the machine.

When a blade is fitted to a flush cutting flange, it is very important for safety to respect the following instructions:

Screw quality and torquing of screws:

The blade must be clamped with countersunk screws and be of quality 10.9. The nuts must be of type "Nyloc" and the fasteners must be torqued with a torque wrench to 35 Nm for M8 screws. The threads must be lubricated with grease or oil.

Warning! *The saw blade must always be fitted correctly to avoid danger. The instructions given above must always be followed to avoid faulty mounting of the blade, which in turn can cause serious personal injury or death.*

Warning! *It is important to be aware of the fact that when a flush cutting blade is used, the blade is clamped merely by the six countersunk screws, nothing else.*

Important! *The blade must have a bolt circle where the holes are spaced on an even and exact pitch to prevent unequal load distribution on the screws, blade and flange*

Warning! *Always keep all part of the coupling clean! The safe operation of the coupling depends on cleanliness of all coupling parts on the machine, and the blade flange!*

Peripheral cutting speed and spindle speed

There are two principal reasons for the peripheral cutting speed to be adjusted:

- The blades are of different diameter for different requirements on cutting depth. The peripheral cutting speed should be approximately the same regardless of diameter. A larger diameter blade will rotate at a lower speed than a small one and vice versa for the same peripheral speed.
- Concrete can be very different depending on the aggregates used, how much steel reinforcement is used etc. Therefore it can be necessary to adapt the peripheral cutting speed to the quality of the concrete, all depending on the type, performance and condition of the saw blade. A rule of thumb is that harder concrete and/or high content of steel is more easily cut with lower speeds than normal concrete, and vice versa.

The frequency from the inverter can be altered to get a useful speed range from approximately 500 to 1050 RPM.

Note: highest motor output power is available when the blade speed potentiometer is set between 80% to 100%. The % indication is a reference to speed, not power output.

The frequency from the inverter is continuously variable to achieve a useful speed range from approximately 870 to 1270 RPM.

Peripheral cutting speed and spindle speed in metres / second for different blade diameters, @ 300Hz: (Set potentiometer at 70% on the remote control)

	\varnothing 600	\varnothing 700	\varnothing 800	\varnothing 900	\varnothing 1000
870 rpm	27.3	31.9	36.4	41	45.5

Peripheral cutting speed and spindle speed in metres / second for different blade diameters, @ 350Hz: (Set potentiometer at 80% on the remote control)

	\varnothing 600	\varnothing 700	\varnothing 800	\varnothing 900	\varnothing 1000
1000 rpm	31.4	36.6	41.9	47.1	Not permitted

Peripheral cutting speed and spindle speed in metres / second for different blade diameters, @ 400Hz: (Set potentiometer at 90% on the remote control)

	\varnothing 600	\varnothing 700	\varnothing 800	\varnothing 900	\varnothing 1000
1160 rpm	36.4	42.5	48.6	Not permitted	Not permitted

Peripheral cutting speed and spindle speed in metres / second for different blade diameters, @ 440Hz: (Set potentiometer at 100% on the remote control)

	\varnothing 600	\varnothing 700	\varnothing 800	\varnothing 900	\varnothing 1000
1270 rpm	39.9	46.5	53.2	Not permitted	Not permitted

The peripheral speeds above in bold style are recommended max speeds for (UK, Paris, Basel, Denmark etc.) type flint, very hard concrete with a high content of steel.

Mounting the blade guard

New safety regulations means that greater emphasis has to be put on safety, and therefore on the blade guards, and these can now, thanks to a new and better design, remain on the machine at all times. A prerequisite to achieve any level of protection is that the guard is fitted to the machine at all times. For the 6-8 HF the blade guards guide is fixed on the saw head. The Pentruder 6-8 HF only uses the "parallel blade guards".

The blade guards are available in two different sizes, Ø 600 (24") and Ø 800 (32") for normal and flush cutting.

The blade guard is automatically controlled by the movements of the saw arm, and the operator does not have to adjust the guard while the machine is running. The guards consist of three main pieces, a middle main piece and two detachable side pieces.

The guard is mounted by sliding the rollers on the blade guard on to the guide fixed on the saw head. A rubber strap is used to keep the blade guard against the cutting surface.

Warning! *The blade guard has many functions. The most important one is to protect the operator and other persons from accidental injury. In a situation when, for example, the operator or someone else accidentally falls against the machine, the guard is there to as well as possible protect against contact with the running blade. In other potentially dangerous situations, for example if a cracked or faulty blade is used, or if the blade is not properly fitted, or the quick release coupling is improperly used, the guard is there to reduce the damage done by a blade.*

Normally the function of the blade guard is to protect the operator and the surrounding area from the water and loose material which is cut away by the blade and thrown out of the cut. To give any protection at all, the blade guard must be mounted at all times when the blade is rotating under power. The instructions above must always be followed. Failure to follow this instruction may result in serious personal injury or death.

Warning! *The blade guard may not be fitted or removed before the two power cords are disconnected from the saw. This rule must always be followed to eliminate that the blade motor is started by accident or the arm or chassis moved when the operator is working on the saw head. Failure to follow this instruction may result in serious personal injury or death.*

Preparing the power pack

Positioning: The power pack should be positioned away from where the sawing takes place **and should be kept dry at all times**. It should preferably be placed on a flat surface.

Do **NOT** leave the power pack outside in the rain. The unit is ventilated but to prevent possible damage to electronic components we recommend that it is kept dry to prevent excessive condensation forming.

Power connections: Electric power to the blade motor is supplied by one 18 mm diameter orange colour 9 m (30 ft) cord. The feed and travel motors are supplied by one smaller diameter orange/grey colour 9 m (30 ft) cord packaged together with a 10 mm water hose. The water quick disconnect coupling with a 90° elbow should be at the saw head end.

Warning! *The power pack should not be connected to the electrical supply until all power cords are first connected to the saw and power pack.*

Connection to water supply:

The power pack is water cooled and needs a minimum of 4 litres (1 gallon) of cool water per minute at full power output. The water pressure should be at least 1 bar (45 PSI) and maximum 5 bar (70 PSI). The water supply may only be connected to the short hose on the power pack water valve.

Important! *In sub zero temperatures the remaining water inside the power pack cooling circuit must be blown out with compressed air. The power must be switched ON, the water valve must be switched ON, the water couplings must be disconnected, and then the water can be blown out using compressed air. Alternatively, if no electric power is available, blow backwards with compressed air in the coupling going to the saw head. The check valve in the water ON/OFF-valve will then open and the remaining water in the power pack can then be blown out.*

Leaving water in the power pack in sub zero temperatures will destroy components in the power pack and potentially cause a complete failure of all electronic equipment inside the box.

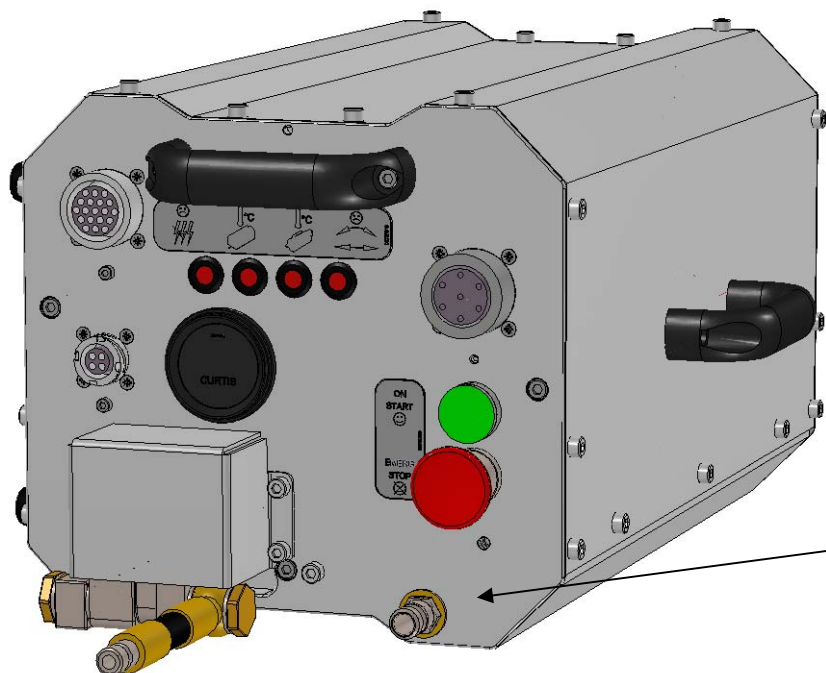

In sub zero temperatures, and if electrical power to the unit is not available, blow with compressed air in this coupling to remove water from the heat sink and tubing inside the power pack.

Connecting to remote control:

The power pack may be disconnected from the mains when the remote control is connected. The multi pin connector must be in the correct position with the notch pointing upwards for the clamping ring to close.

Power supply:

The power pack must be connected to a 5-pin 380 - 480 V 3-phase supply with minimum 16 Amp fuses. A neutral is NOT needed other than for the 230V single phase outlet.

Connecting to mains:

The power pack is equipped with a 32 Amp receptacle. To use other sizes than 32 Amp plugs an adaptor must be fitted.

The power pack may be electrically disconnected from the mains when the power cords between the power pack and saw head are connected.

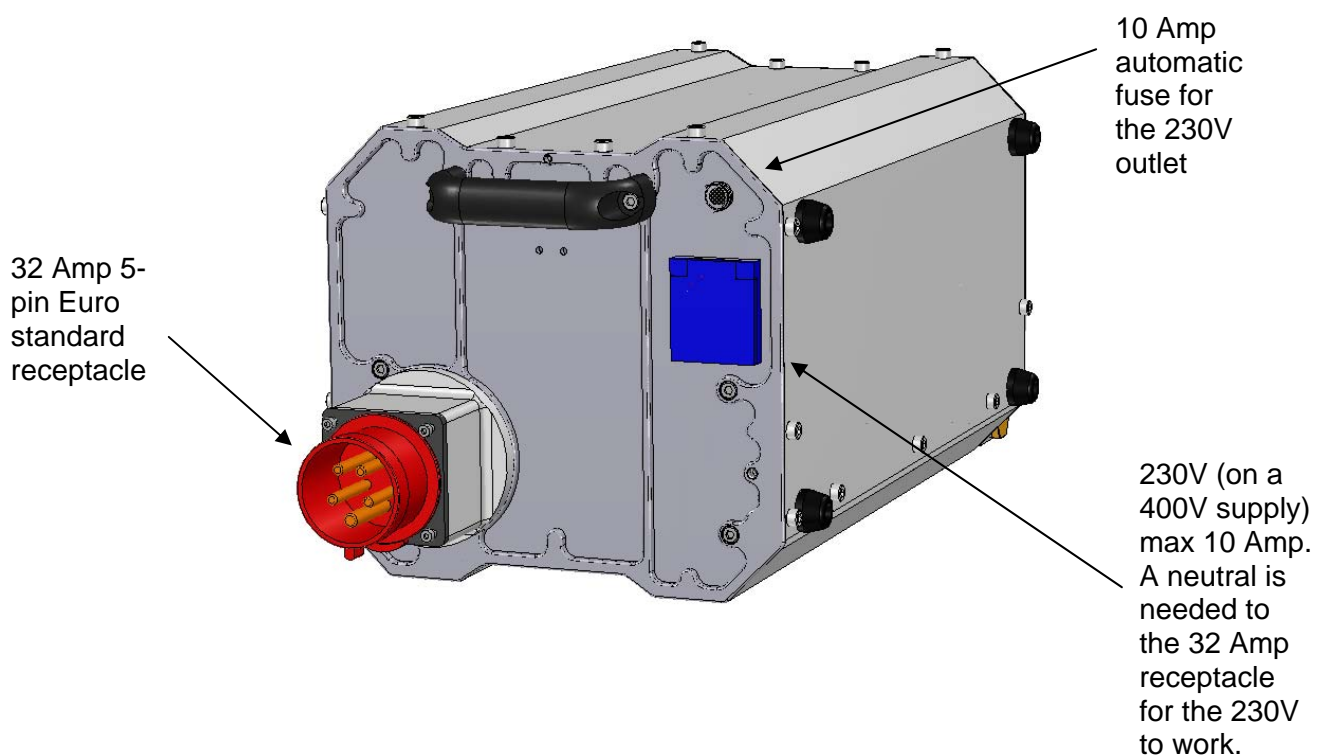

Starting the power pack:

Connect all cords, big diameter orange colour cord to HF-motor, small diameter orange colour cord to feed and travel motors, grey remote control cord to the power pack and lastly a 380 – 480V 3-phase cord to the mains. Then press the green push button. A green light in the button should then come on.

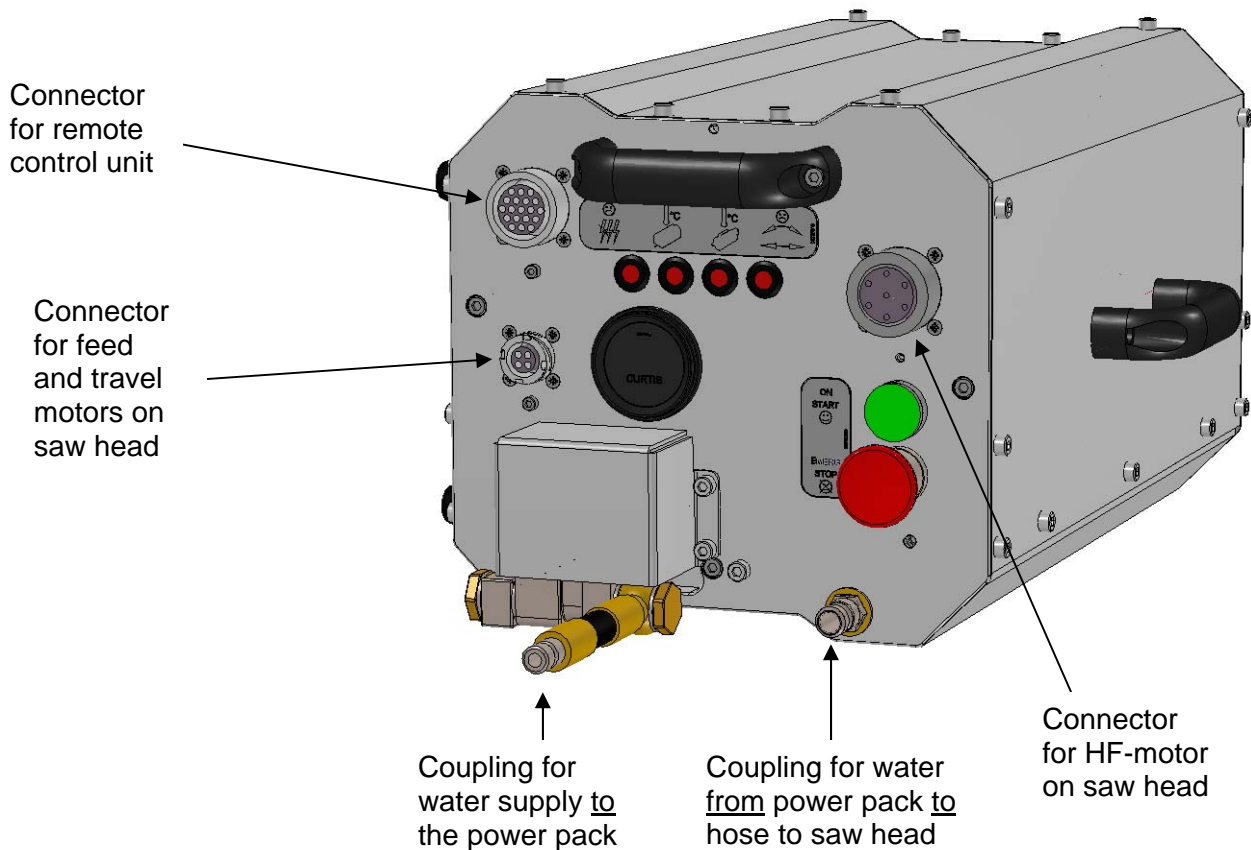

LED type warning lights on the power pack

There are four red warning LED:s on the Pentpak 418. Below is an explanation of the respective functions.

LED for loss of one or more incoming phases

One blink:



Loss of phase on mains. Loss of one power supply phase line can be caused by a blown fuse, faulty cords, faulty plugs or receptacles, or other problems. If the light is on, check fuses, input voltage, cords etc.

Two blinks:

Too low incoming voltage. Check voltage, connectors and cords.

Three blinks:

Too high incoming voltage. Check voltage. Connect to only 3-phase 380 – 480V.

With one phase missing from the power supply, feeding may work, but the blade will not rotate.

General advice to eliminate any of the above fault conditions: Eliminate the cause of the problem, i.e. replace blown fuses, repair cords, repair or replace plugs and receptacles.

Note: To allow capacitors in the inverter to discharge, at least one minute must elapse after the emergency stop button is pressed and the green start button is pressed.

LED indicating status for the power pack

One blink:



Overcurrent alarm. The blade motor has shut off due to overload, reset by restarting blade, wait 15 sec, then start again.

Two blinks:

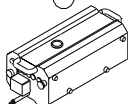

Temperature in the frequency inverter has risen to a too high level. Protect from direct sunlight, increase water flow.

Three blinks:

Other alarm for frequency inverter. Unplug the unit from the power supply, wait at least one minute and plug it in again. If the alarm has gone away you can proceed as normal. If the alarm doesn't go away, the unit must be checked by a technician trained on this equipment.

Four blinks:

Frequency inverter alarm. Must be checked by a technician trained on this equipment.

LED for indication of loss of one or more phases

LED indicating status for the power pack

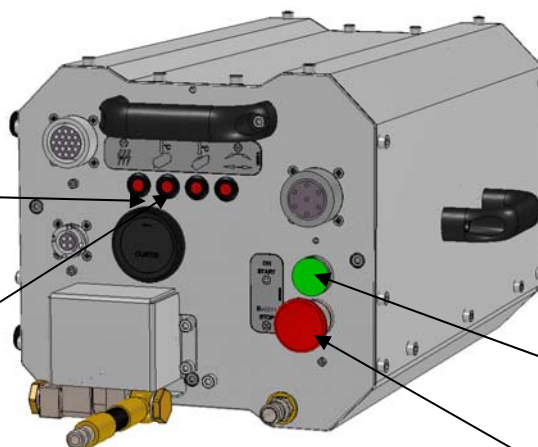

Start button

Emergency stop button

LED indicating status for the HF-motor

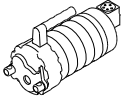

One blink:	 °C	HF-motor automatic identification is not working correctly
Two blinks:		HF-motor temperature sensor in windings is not working correctly
Three blinks:		HF-motor or HF-cable is not working correctly
Quick blinks:		HF-motor temperature is high, output power is automatically reduced
Light is on all the time:		HF-motor temperature is too high. The HF-motor will be switched off

Note: The motor will be switched off automatically when the motor winding temperature is over 140°C (284°F). The coolant water should then be left running through the power pack and HF motor to avoid terminal overheating.

Note: If the water is turned off after the motor has been switched off automatically, and when the warning light is on, terminal damage to the motor windings may occur.

Note: The outside temperature of the motor is no indication of the inside temperature of the motor. The temperature sensor is placed inside the motor windings and does not monitor the outside temperature of the motor. The windings can be working at a high temperature even if the motor is cold on the outside. Note: The warning light will be off when the temperature has gone down to a temperature below 110°C.

LED indicating status for the feed and travel drive system

One blink:		Indicates short circuit in cables and or feed-motors.
Two blinks:		Indicates low voltage on the 24V supply internally, Must be checked by a technician trained on this equipment.
Three blinks:		Automatic identification of machine type not working correctly.
Continuously on:		When this light is flashing, the temperature of the servo is too high. If the light is on at all times it is overheated. Push the emergency stop button to reset.

The DC-servo supplies the feeding motors with power so if this lamp is on, the blade will start but there is no feeding available. The servo alarm indicates that the built in protection of the DC-servo is overloaded, or that it has detected a short circuit, or that there is a problem in one of the connectors or the 24V DC cable to the saw.

The servo alarm can also indicate that there is some electrical malfunction.

After restarting the power pack, this electrical disturbance from the mains may have disappeared. If the servo alarm LED is on before the work is started, i.e. the machine is connected, but not started, this indicates a short circuit in the cables/connectors to the one or both feed motors.

To reset the alarm, press the emergency stop button and wait until the alarm lamp goes out. Then press the green start button to start the power pack again.

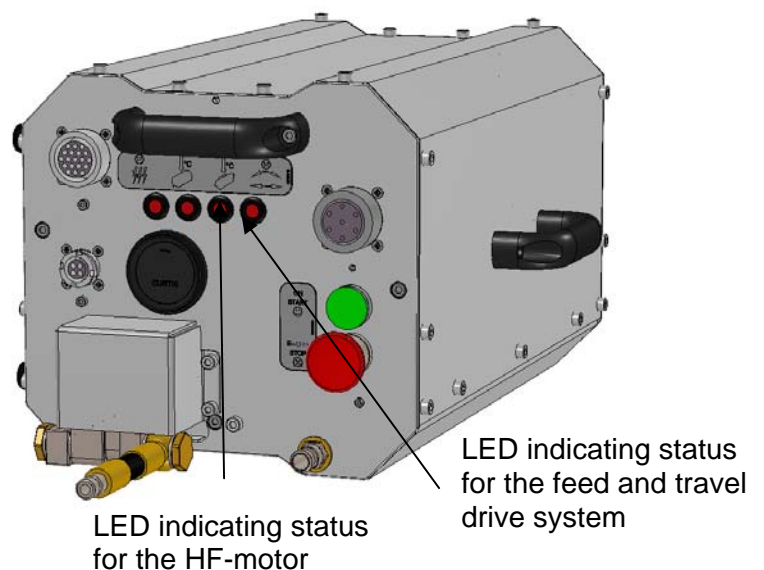

Remote control unit

The remote control unit is connected to the power pack through a Cannon connector. It is not possible to control any functions on the power pack unless the remote control is connected to the power pack.

Available functions:

Switch for Blade

Motor ON/OFF:

First push forward and hold the switch for Water ON/OFF and then push the Blade ON / OFF switch forward to start the blade. To stop the blade, push the Blade ON / OFF switch forward once again.

Switch for water valve: Move the switch forward to start and stop the water flow through the machine. The water flow will be switched on automatically when the blade is started. The water will be left running when the blade motor is stopped and the water must be switched off manually.

Potentiometer for blade speed control:

The minimum speed is set at 70% of the maximum speed. Full power is available when the potentiometer knob is between 85 % and 100 % on the potentiometer scale. At its maximum CW position, i.e. 100%, the motor power output is slightly reduced, by approximately 0.4 kW.

Potentiometer for feed and power regulation:

As long as the blade is spinning in the air, the potentiometer is used only to control rapid feed of the machine. From the moment the blade touches the concrete and a preset amperage draw is exceeded, the potentiometer changes its function and is then used to control the power used to drive the blade.

Between 80 - 100% the system will always try to reach maximum power. At 100 % the feed regulation is more aggressive than at 90 or 80%, but the machine will always try to reach maximum power also at the 80% or 90% setting. If the potentiometer is turned below 80% the power output will be reduced correspondingly.

Joystick for control of the movement of the saw head and radial arm:

Flick the joystick up or down to rotate the radial arm. Flick the joystick left or right to move the saw head along the track.

In case of a jammed Blade:

The power pack has an automatic function for resetting the frequency inverter if the blade is jammed. Move the blade out of the cut, or at least to a position where it can be started without too much resistance, and press the blade ON/OFF switch forward once, then it takes approx 15 seconds for it to reset. Certain reset procedures are activated depending on how sudden the stop was.

If the blade is jammed very, very abrupt, the reset procedure might not be enough. In this case you need to unplug the unit from the power supply, wait for 30 seconds and plug it in again.

NOTE : If one of the emergency stop buttons are pressed or the unit has been unplugged from the power supply, both the blade speed and the feed and travel potentiometer must be returned to zero before the machine is operational again.

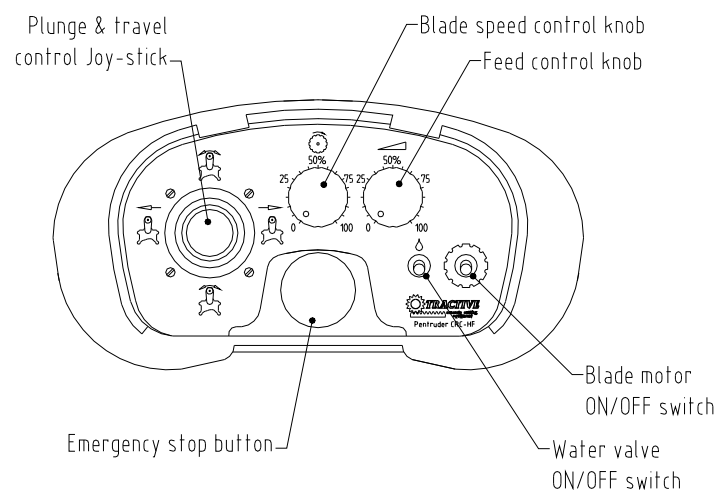

Maintenance

For the Pentrunder 6 - 8 HF Lean/ Pentpak 418 to remain in a condition which is safe for operation at all times, certain maintenance is needed. Please read the instructions below carefully before any service work is commenced.

For safe and uninterrupted operation of the machine, we strongly recommend that the complete machine is brought back to your dealer for service at least once per year. At this service the machine is checked for proper function and all components critical for safe and reliable operation are checked and replaced if necessary.

Please respect the following maintenance instructions:

Warning! *No service or maintenance may be performed on the power pack unless it is disconnected electrically from the mains.*

Warning! *No service or maintenance may be performed on the saw head unless it is disconnected electrically from the power pack.*

Bolts for flush cutting blades:

Always replace worn or damaged bolts with new of correct length and quality, 6x M 8, 10.9 countersunk screws.

Cleaning:

The machine should be carefully cleaned and all functions checked and found normal before use of the machine. If a high pressure cleaner is used, the nozzle may **NOT** be pointed at rotating parts on the machine. Avoid pointing at seals and electrical connectors.

Cords and connectors: Check that all cords and connectors are in faultless condition.

Track guide rollers:

Check that the track guide rollers on the saw head can move freely without too much friction. A certain amount of friction is always present as the bearings are double sealed with both rubber and steel scraper seals.

Oil change in the arm transmission:

Change oil every 80 hours of operation. Before attempting to change oil, **and this is very important**, clean thoroughly around the plug and blow with compressed air before the plug is removed. If dirt is allowed to enter the gearbox, the gearbox may seize and any warranty is void. To change oil, unscrew the oil-plug and drain the arm completely. Refill with 0.145 L (0.15 quart) of gearbox oil Omega 690 (synthetic oil with 75W viscosity). The oil must meet GL5 specifications. Clean the plug, fit it and tighten again.

Oil change in the HF-motor high speed transmission:

This oil change may only be carried out by a trained technician familiar with this machine. **Change oil every 80 hours of operation.** Before attempting to change oil, and **this is very important**, clean thoroughly around the HF-motor and blow with compressed air before the HF-motor is removed. If dirt is allowed to enter the gearbox, the gearbox may seize and any warranty is void. Remove the HF-motor and drain the gearbox completely. Fill up to the bottom of the hole for the gear on the HF-motor, sawhead should be horizontal, with **clean and preferably filtered** gearbox oil Mobil SHC 626 (synthetic oil with 75W viscosity). The oil must meet GL5 specifications. Clean and re-fit the motor, tighten with the correct torque.

Worm gear Transmission (travel and arm feed):

Change oil every 80 hours of operation. Fill with 180 ml (0.19 quart), or to full with Mobil SHC 626.

Cooling housing at rear of motor:

Change oil every 80 hours of operation. Fill with 85 ml (0.09 quart) of Mobil SHC 626.

Overload clutch:

If any of the overload clutches have been overloaded or worn out, a trained mechanic can repair the coupling by replacing the clutch plates, but we recommend that the machine is brought to your dealer for service.

Digital communication connectors:

Check all connectors for proper function and replace when necessary. All parts in the connectors are available (except remote control connector). All wires can be re-installed with standard hand tools (except remote control connector).

Remote Control unit:

Check the remote control unit for correct function and that the connector is clean and undamaged.

Technical data Pentrunder 6-8HF

Maximum saw blade	Ø 800 mm
Maximum cutting depth	350 mm (Ø 800 mm)
Max start Ø of blade	750 mm
Saw blade arbor Ø	60 mm
Spindle speeds:	870 rpm@300 Hz 1000 rpm@350 Hz 1160 rpm@400 Hz 1270 rpm@440 Hz
	Continuously variable from 300 Hz to 440 Hz, set potentiometer to control
Travel	DC-motor
Max travel speed	2.3 m/min
Feed	DC-motor
Max arm rotational speed	1.8 rpm
Water feed	Central through blade flange
Blade flange diameter	98 mm with centre bolt or flush cutting flange
Weight of saw head complete with motor	26.3 kg

Track system

Track feet:	Universal aluminium and steel
Weight:	2.4 kg
Track 0.85 m, weight:	3.7 kg
Track 1.15 m, weight:	4.9 kg
Track 1.7 m, weight:	7.3 kg
Track 2.0 m, weight:	10.9 kg
Track 2.3 m, weight:	12.7 kg

Technical Data Pentpak 418 HF Power Pack

Input voltage:	380 – 480 V
Input frequency:	50 – 60 Hz
Input power:	max 21 kW
Fuse:	minimum 16 Amp, preferably 25 Amp @ 400V 32 Amp receptacle
Recommended diesel generator size:	30 kVA
Maximum continuous output power (with 15 kW motor):	15 kW
Output voltage to feed and travel motors:	24V DC
Weight:	26 kg
Height (incl. handles, connectors, etc.):	28 cm (11")
Width (incl. handles, connectors, etc.):	30 cm (11.8")
Length (incl. handles, connectors, etc.):	68 cm (26.8")
Remote control Weight :	1.3 kg (2.87 lbs) (2.4 kg (5.3lbs incl. cable)

EC-declaration of conformity

We, **Tractive AB** declare that the machine

Manufacturer: Tractive AB
Gjutargatan 54
78170 Borlänge
Sweden

Category: High Frequency Power Pack
Make: Pentpak
Type: 418

Is in conformity with the provisions of the Machinery Directive 2006/42/EC.

Is in conformity with the provisions of the following other EC-directives:

- Low Voltage Directive 2006/95/EC
- EMC-Directive 2004/108/EC

In accordance with the EC-declaration of conformity, the product must not be modified without the manufacturer's permission. If this occurs, this documented EC-declaration ceases to apply and the modifier is considered to be the manufacturer and must verify and draw up an addendum to the EC-declaration and file technical data for the inspection authority.

Gjutargatan, Borlänge, 2nd of January, 2011



Anders Johnsen

Technical Director

EC-declaration of conformity

We, **Tractive AB** declare that the machine

Manufacturer: Tractive AB
Gjutargatan 54
78170 Borlänge
Sweden

Category: High Frequency Wall Saw

Make: Pentruder

Type: 6-8HF

Is in conformity with the provisions of the Machinery Directive 2006/42/EC.

Is in conformity with the provisions of the following other EC-directives:

- Low Voltage Directive 2006/95/EC
- EMC-Directive 2004/108/EC

In accordance with the EC-declaration of conformity, the product must not be modified without the manufacturer's permission. If this occurs, this documented EC-declaration ceases to apply and the modifier is considered to be the manufacturer and must verify and draw up an addendum to the EC-declaration and file technical data for the inspection authority.

Borlänge, 2nd of January, 2011



Anders Johnsen

Technical Director