

**Operator's manual for
Pentruder® 6-12HF-wall saw and
Pentpak® high frequency power pack**



**Version: 1.9 Date: 2012-03-05
Support & Service document
Original instructions**



Copyright © 1997-2012 Tractive AB.
Pentruder and Pentpak are registered trademarks belonging to Tractive AB.

Contents

Introduction	2
Description of the machine.....	3
Saw head Pentruder 6-12HF with accessories	3
Quick disconnect coupling for mounting of the saw blade (Patent).....	6
Tracks and brackets.....	7
Blade guard.....	8
Pentpak high frequency (HF)-power pack	9
Design, function and special features of the Pentpak HF-power pack	9
Intended use of the Pentruder 6-12HF and Pentpak HF-power pack.....	10
Safety precautions	10
Getting started	12
Preparations before commencing work.....	12
Preparation and mounting of track feet and tracks	14
Mounting the saw head on the track	16
Quick disconnect coupling for HF-motor on saw head.....	17
Quick disconnect coupling for the saw blade	18
Function principle:.....	18
How to fit a blade on a standard blade flange:	19
How to fit a blade on a flush cutting flange:	20
Mounting the blade with flange on the machine spindle	21
Peripheral cutting speed and spindle speed	21
How to choose correct gear and cutting speed	22
How to shift gears in the 2-speed gearbox:	24
Mounting the blade guard	25
Preparing the power pack	26
LED type warning lights on the power pack.....	28
Remote control unit	32
Maintenance	34
Technical data Pentruder 6-12HF - HF-wall saw	38
Technical data Pentpak HF power pack	39
Declaration of Conformity.....	40

Introduction

Thank you very much for your confidence in our product! You have chosen to invest in a product which will give you many years of efficient and profitable production. The Pentruder 6-12HF has been developed based on more than 25 years of experience in this specialised field. With correct handling it offers outstanding performance, safety and reliability.

It is essential that all personnel working with, or in close proximity to, the saw have read and understood the contents of this manual before commencing operations. Only by reading and understanding the manual will the operator be able to take advantage of the many features and benefits of the Pentruder 6-12HF. We are confident that your investment in this equipment and its many design features will enhance your companies' competitive edge and profitability!

The first section of this manual, page 1-2, contains the table of contents and an introduction of the machine.

The second section of this manual, page 3-11, contains a general description of the machine and explains the different features which make the Pentruder 6-12HF to one of the safest and most efficient machines available on the market today.

The third section of this manual, page 12-33, contains a description how to get started with the machine. Please take careful note of the Safety Precautions.

The fourth section of this manual, page 34-41, contains instructions how to maintain the equipment, and technical data.

Important! When you read this manual it is important that you read and understand what is said about safety under the headlines "**Important**". In those paragraphs beginning with "**Important**" we inform about risks connected with use of the machine, and, if the safety precautions are not respected, can result in damage to property and persons in close proximity to the machine.

Warning! When you read this manual it is important that you read and understand what is said about safety under the headlines "**Warning**". In those paragraphs beginning with "**Warning**" we inform about risks connected with use of the machine, and, if the safety precautions are not respected, can result in serious injury and even to fatal injuries to persons in close proximity to the machine,.

To avoid serious or even fatal injury to the operator and persons in close proximity to the machine, it is important that the machine always is operated by trained, responsible personnel.

Description of the machine

The Pentruder 6-12HF represents a very modern and safe type of concrete wall saw. The Pentruder 6-12HF was developed and manufactured by **Tractive AB** in Sweden in a process where safety awareness, performance and reliability were the most important design parameters.

By taking advantage of experience and know-how built up over many years in this specialised field, this new design can offer the user great advantages, for example the markets best performance to weight ratio.

The Pentruder 6-12HF offers outstanding quality. It is the culmination of exacting goals for quality and safety set at every stage from concept to finished product.

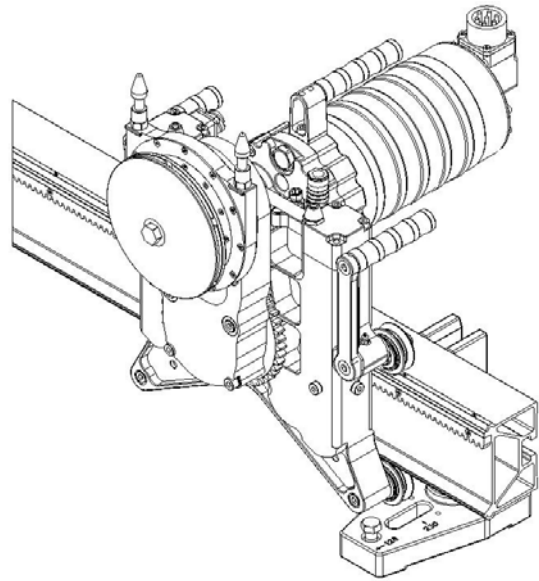

Saw head Pentruder 6-12HF with accessories

Warning! The guard must be fitted whenever the machine is run.

The Pentruder 6-12HF is the overall most efficient machine for concrete cutting in it's size available on the market today. When the overall efficiency of the system is evaluated, all aspects of the work must be considered. The features of the 6-12HF mentioned below all contribute to make your work safer, easier and more efficient.

- Low weight, only 21 kg for the saw head less motor, and 13 (28.6) kg for the 15 kW (20 HP) or 16.5 (36 lbs) for the 18kW (24HP) motor. For efficient cutting with blades from Ø 800 (32") to 1200 mm (48") diameter.
- Lightweight saw head built from aircraft quality components machined from solid aluminium. No castings are used.
- **Pos A.** Quick release coupling for HF-motor on saw head. To put the motor on the saw head or to remove it takes just a few seconds.
- **Pos B.** Quick release mechanism of saw head to and from track. Eccentric rollers on the saw head allow it to be fitted and removed from the track with ease.
- **Pos C.** Superior blade mounting system by patented quick release coupling.
- **Pos D.** 2-speed gearbox for optimum performance. The precision engineered gearbox offers unsurpassed performance and high efficiency in the transmission. The integrated gearbox simplifies the correct choice of peripheral cutting speed to match a chosen blade diameter.
- **Pos E.** Conical self cleaning guide rollers offers optimum control of the saw head along the track. The rollers are easily adjustable and offer reliable operation over a long period of time. The guide rollers are arranged in the same plane as the saw blade for optimal force distribution.
- **Pos F.** Oil lubricated speed reduction gearbox with precision ground helical gears.

- For optimum accessibility the saw arm can be rotated through 360 degrees in either direction.
- The saw head accepts an 800 mm (32") saw blade free from the wall.
- Double motor cooling system, i.e. both rotor and stator are cooled, for sustained reliable power and high efficiency.
- Efficient water supply to blade central through blade flange, even for flush cutting blades.

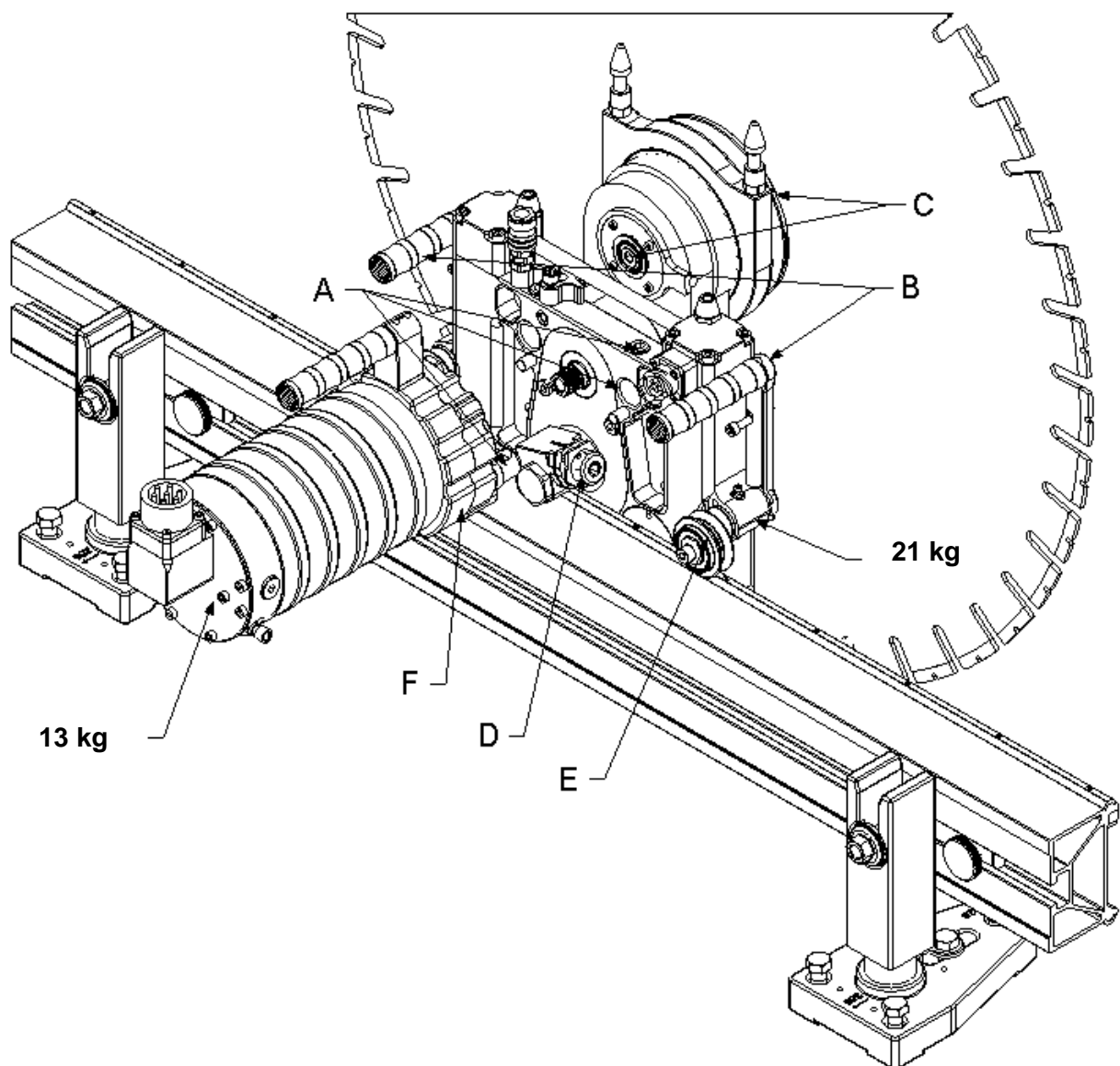

- **Pos G.** Travel and feed motors are protected within the chassis body. No electric parts except for connectors are exposed to dirt.
- **Pos H.** Travel and feed transmission is by means of planetary gear transmission and a self blocking worm gear transmission. No risk for unexpected movements of the saw head as a result of a failed electric motor brake.
- **Pos J.** The worm screws are supported by oil lubricated axial needle roller bearings and axial thrust ball bearings.
- **Pos K.** Main HF-motor has a long life multi plate slip clutch for protection of the gear train if a blade is jammed. The slip clutch can easily be removed and serviced if needed.
- **Pos L.** The arm rotation transmission is protected by a multi plate slip clutch if a blade is jammed. The operator can just “move back” from the cut and start again. Also this slip clutch can easily be removed and serviced if needed.
- **Pos M.** The lower pair of conical rollers are adjustable by means of eccentric shafts.

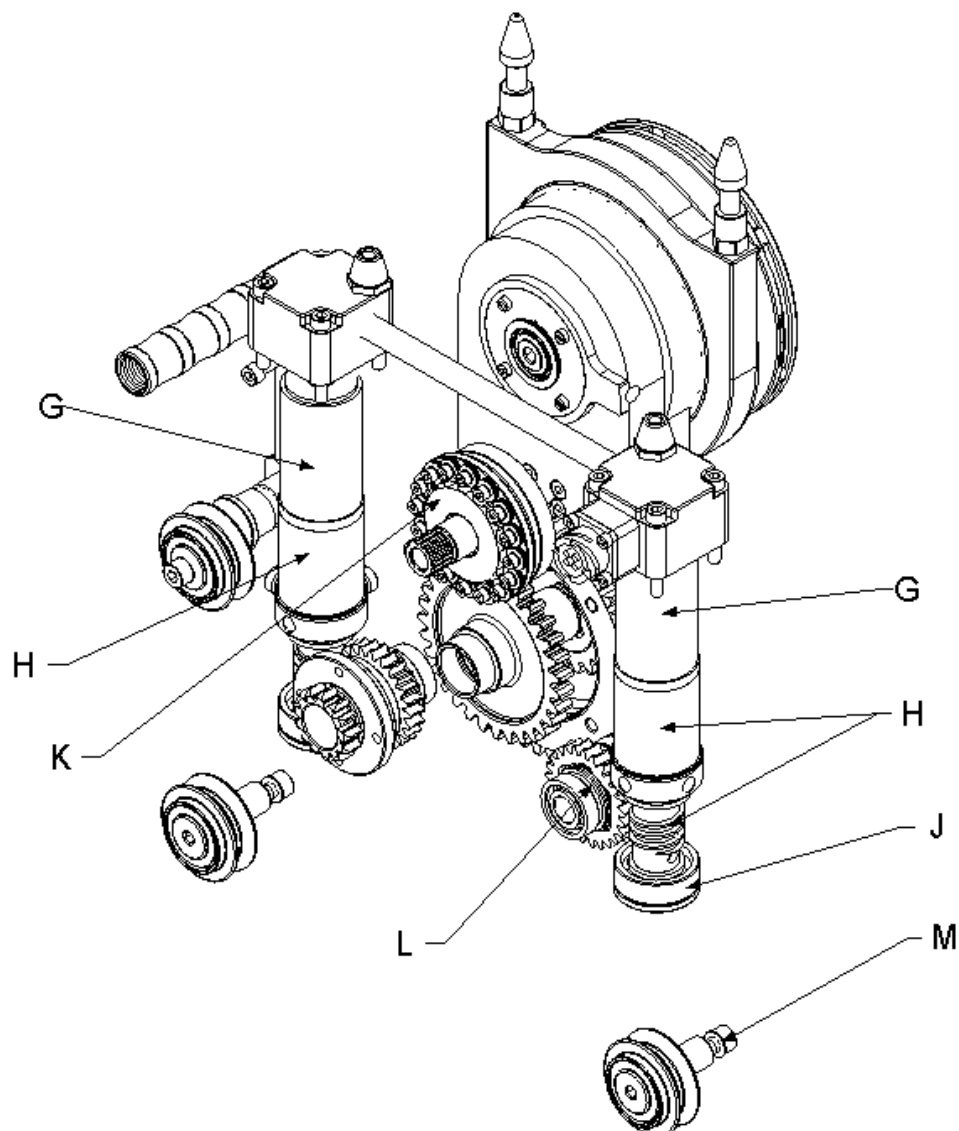

Quick disconnect coupling for mounting of the saw blade (Patent)

Tractive AB puts great emphasis on creating technical solutions for its products that are safe to use. This is the most important criteria when our machines are designed.

- Pentruder 6-12HF is equipped with a patented quick disconnect coupling for the saw blade. The intention with this coupling is primarily to enhance safety and handling. A unique patented coupling for the blade flange enhances safety and simplifies awkward set-up's considerably, especially when flush cutting must be performed. The saw blade can always be fitted, after the machine is mounted, radially, and heavy and troublesome set-up's can be eliminated to a great extent.

Mounting a saw blade for flush cutting has always been relatively awkward and often one must mount the saw head and the saw blade together, and it can be difficult to mount also a normal saw blade for the upper or the lower cut, or even for vertical cuts if the available space is limited.

- With Pentruder's quick disconnect all these problems are gone. Provided the operator is trained in the correct operation of the coupling it will provide considerable improvement on both safety and efficiency.

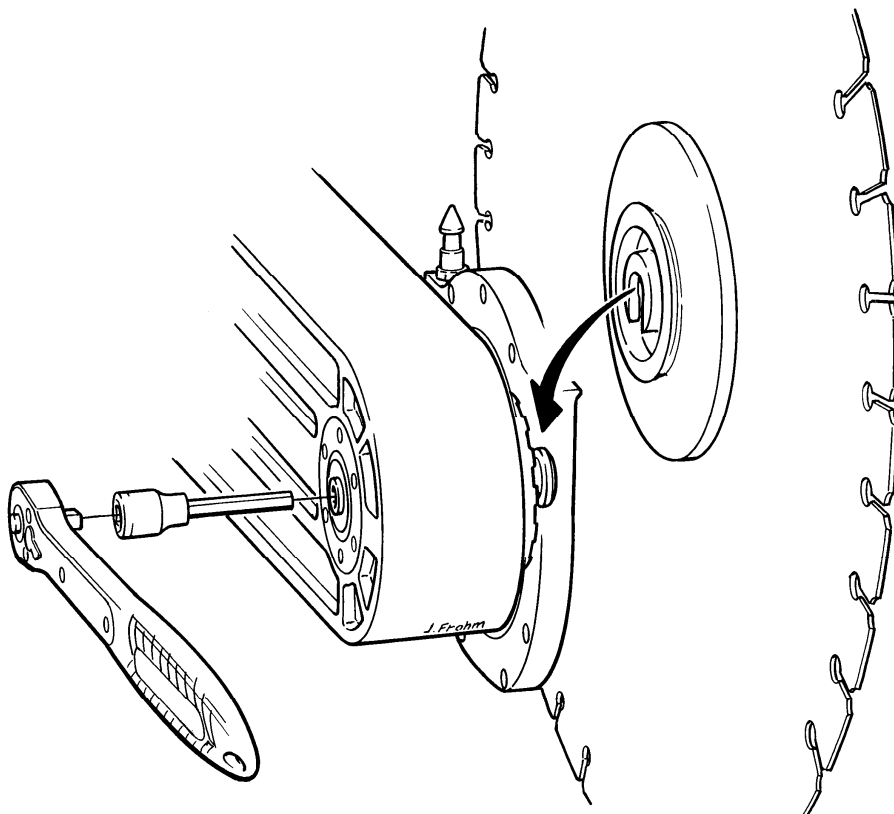

Tracks and brackets

The tracks and the brackets are designed to provide high levels of rigidity and stability for the lowest possible weight. The design is unique in the sense that it allows the guide rollers on the saw head to be aligned above each other, in the same plane as for the cut. This is to provide the highest levels of safety, stability and precision of cut.

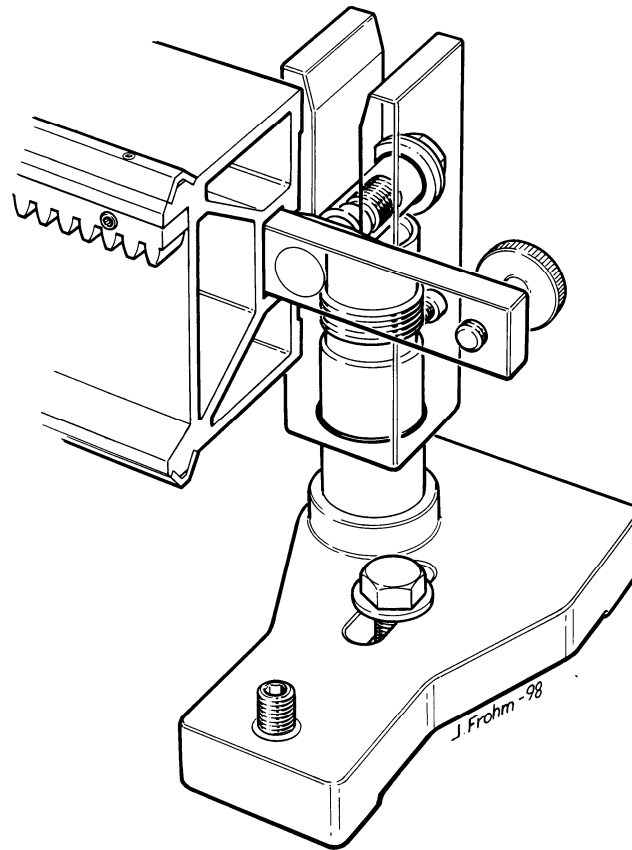

- The tracks are very lightweight at only 6.95 kg / m (4.5 lbs. per foot) track. The stiffness and stability in the system is still, in spite of the low weight, sufficient for heavy loads and jobs where up to 2 m (78") diameter blades are used (with another wall saw).
- The tracks have steel guide rails on which the rollers run. They offer high wear resistance and precise guidance of the saw head. The grooves into which the guide rails are located have been machined with great precision.
- The tracks are quickly and easily mounted in an easily accessible yoke by means of a T-slot piece, which in turn is provided with a lubricated and protected screw and case hardened sleeve-type nut. The hardened sleeve-type nut safeguards that the screw preload is always adequate to clamp the track. This system improves safety and reduces the possibility of the nut working loose because of vibration or variations in load.
- The brackets are versatile and easy. A minimum of two brackets are needed to fit one track. When two tracks are joined, at least three brackets must be used, one of which must be mounted directly over the joint between the two tracks.

Blade guard

The blade guards are made from sheet metal of hardened aluminium, screwed together with spacers to achieve strength and stiffness. For the 6-12 the blade guards are available in three different sizes, Ø 800 (32"), Ø 1000 (40") and Ø 1200 (48") for normal and flush cutting. Fully covering blade guards are also available. These are used together with a parallel blade guard guide.

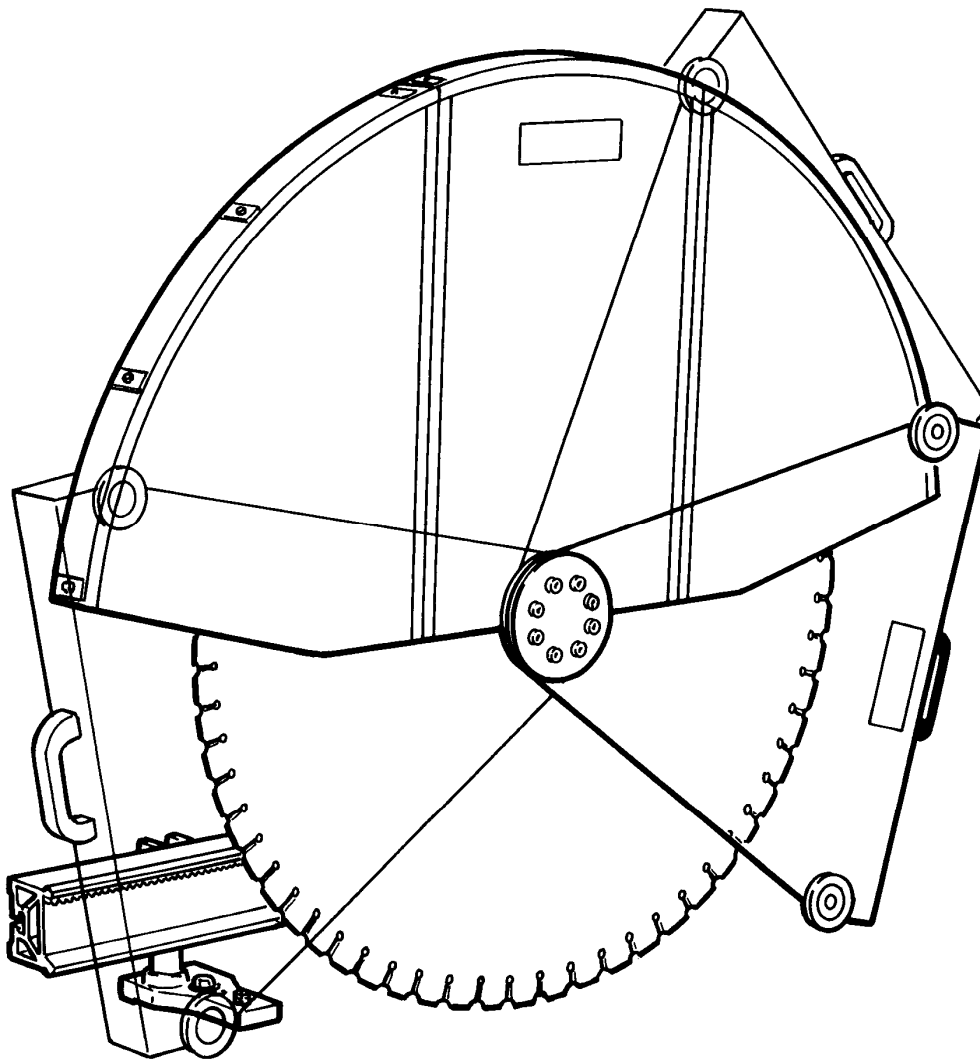

- New regulations put new and higher demands on safety, and thereby on the blade guards. Because of the lightweight design it is more likely that the operator will choose to use the blade guards on all jobs – this has not always been so! The guards on the Pentrunder 6-12 HF are so convenient and lightweight they should always be used. It is a basic requirement for safe handling of the machine.
- Spray from the saw blade is reduced thanks to the extra swivelling guard piece.
- Automatic control of the blade guard through the movement of the saw arm, the operator need not adjust the guard manually while the machine is in operation.
- Detachable side pieces. The guards are divided in three pieces with a fixed centre piece and two detachable side pieces for cutting into adjacent surfaces.

Pentpak high frequency (HF)-power pack

The Pentpak high frequency (HF-)power pack is designed to a new and unique concept. The electronic units are especially designed for the Pentpak and the power pack is one of the most compact designs on the market. It offers outstanding performance combined with reliability, safety and ease of handling.

Depending on voltage and chosen HF-motor there are different HF-power packs.

For 380 – 480 V Input voltage there is the Pentpak 427 for up to 27 kW HF-motor, Pentpak 422 for up to 22 kW HF-motor (this power pack is no longer sold) and Pentpak 418 for up to 18 kW HF-motor. For 200 – 230 V Input voltage there is the Pentpak 200 for up to 22 kW HF-motor (400 Hz input frequency), the Pentpak 218 for up to 18 kW HF-motor and the Pentpak 222 for up to 22 kW HF-motor. In the following operator's manual Pentpak HF-power pack or just Pentpak is used to refer to all of the Pentpak HF-power packs listed above.

New regulations for the design of machines and the specifications for their inherent safety have been the ruling parameters in the design and development of this power pack.

Design, function and special features of the Pentpak HF-power pack

- For optimum safety and manoeuvrability all functions are controlled through a remote control unit. The operator can therefore always be in the safest and best possible position and still have full control of the machine.
- The remote control system contributes to a high level of safety. All functions are reset automatically when the power supply is disconnected, or when any of the Emergency Stop-buttons are depressed. The blade, if in rotation, and in a cut, will continue to rotate because of its inertia, but will coast to a stop after a few seconds. If the blade is rotating and not in a cut, it will take longer before the blade stops. No functions remain after the power pack has been shut off. At every restart the power pack starts from the same initial mode with all functions reset.
- The converter is water cooled which provides excellent cooling of the transistor power modules in the frequency inverter.
- If the power pack is run using an inadequate supply of cooling water, it is still protected from overheating by means of a temperature sensing device inside the power pack.
- The Pentpak HF-power pack is compact and weighs only 26 kg, still it can drive the electric motor with a continuous output of up to 27 kW depending on model.
- The power pack has a high overall efficiency factor and at 400 V a 32 Amp delay fuse will be enough to run the power pack and motor at their maximum rated output. We recommend to use a 40 Amp fuse if possible. Even 16 Amp (25 Amp for the 27 kW HF-motor) delay fuses can be used but then the power output must be reduced by turning the feed rate knob on the remote control.
- All electrical and electronic equipment is protected under covers and can not easily be tampered with. The only device that can be operated is the (green) start and emergency stop buttons.

Intended use of the Pentruder 6-12HF and Pentpak HF-power pack

Pentruder 6-12HF is intended to be used together with a Pentpak HF-power pack and may only be used for cutting of concrete and similar materials. It is our expressed recommendation that the machine **not** be used for cutting in any other materials. The Pentruder 6-12HF saw head cannot be used with other types of power packs. If connected to other types of power packs (frequency inverters) Tractive AB disclaims any responsibility for the product.

Warning! Please observe that Tractive's responsibility as a manufacturer can only be accepted when the saw head, Pentruder 6-12HF, is used together with power packs, machines and accessory equipment of Tractive's manufacture and origin. If the Pentruder saw head is used with non-original equipment the warranty will be void.

The Pentpak is primarily intended to power Pentruder HF-wallsaws. It is also used for powering other machines of our manufacture, like the MD1, 4-speed drill gearbox, as well as our wire saws. Please contact your distributor for information. Please observe that Tractive's responsibility as a manufacturer only can be accepted when the Pentpak is used together with machines and accessory equipment of Tractive's manufacture and origin.

Important! Always consult Tractive AB or our representative before any other type of machine or equipment than the Pentruder 6-12HF is connected to the power pack. Observe that Tractive's responsibility as a manufacturer can only be accepted when the saw head Pentruder 6-12HF is used together with power packs, machines and accessory equipment of Tractive's manufacture and origin. If the Pentruder saw head is used with non-original equipment the warranty will be void.

Safety precautions

It is of paramount importance that the operator has full knowledge and understanding of the instructions below:

This wall saw may not be used unless the operator is fully familiar with the contents of this manual and has been trained in its operation by an authorised distributor of Tractive AB's products. The operator is fully responsible for the manner in which the machine is operated. It is the responsibility of the purchaser that the operator has received the information needed to operate and handle the machine in a safe and correct way.

Warning! Faulty handling of the machine can expose the operator and / or persons in close proximity to the machine to extreme danger.

Tractive AB disclaims all responsibility for damages to persons and / or property resulting from use of the machine, whether they are caused by faulty handling or from damages that have occurred as a consequence of negligent or faulty maintenance, or as a consequence of failure to check and control the machine with regard to damages and / or faults.

Warning! A Pentruder wall saw used in the correct way is a safe and efficient tool. If the machine is used improperly this can expose the operator and other persons staying in the same area to extreme danger or even risk of fatal injuries.

Warning! Basic safety precautions are that all persons present in the same area or in the same place as the machine shall wear protective equipment including helmet, safety shoes, gloves, eye and ear protection, and that all other safety precautions applicable on site are to be respected.

Warning! Track stops must always be securely mounted at each end of the track(s) to prevent the saw head from being run off the track unintentionally.

Warning! A saw blade rotates at up to 60 m/s peripheral speed, i.e. over 200 km/hour (120 mph). The energy stored in such a blade is considerable, and it is always important that the machine always is mounted according to the instructions given in this manual, and that the blade guard **always** is fitted.

Warning! Always check that the equipment is in faultless condition and that all functions are in order before work is commenced.

Warning! Never connect the power cord from power pack to the HF motor while the power pack is switched on. Press at least one of the Emergency Stop buttons before the power cord is connected to power pack and HF-motor.

Warning! The power pack must always be switched off and the 32 Amp plug and cable disconnected from the power pack before any kind of service or repair is commenced.

Warning! Mounting and dismounting of the saw head may only take place when the saw head is disconnected from the power pack by removing the power cord from the saw HF motor and the 24V DC cord to the feed and travel motors.

Warning! Mounting and dismounting of the **blade guard and saw blade** may only take place when the saw head is disconnected from the power pack by removing the power cord from the saw HF motor and the 24V DC cord to the feed and travel motors.

Warning! Track brackets may only be mounted according to the instructions given in this manual.

Warning! To maintain the level of safety inherent in the design of this machine, only Tractive original spare parts may be fitted. Tractive AB disclaims all responsibility for any damage occurring as a result of use of non original parts.

Important! The power pack should preferably only be operated when it is put on its back with the hour meter pointing upwards.

Important! The power pack is water cooled and must be drained from water when the ambient temperature is in the proximity of or below 0 degrees Celsius. To drain the power pack completely in sub zero temperatures, switch off the blade motor, disconnect water supply, switch on water on the remote and blow out all water with compressed air. Alternatively, if no electric power is available, blow backwards with compressed air in the coupling going to the saw head. The check valve in the water ON/OFF-valve will then open and the remaining water in the power pack can then be blown out.

Important! The power modules in the power pack are water cooled and the water pressure must therefore be limited to max 5 bar. The incoming water supply may only be connected to the short hose on the water ON/OFF valve on the power pack. The quick disconnect couplings may not be replaced with couplings that are not fully open when disconnected.

Important! Connect the power pack only to Pentruder HF-wall saws, Pentruder Wire Saws, HF-drill motors or any such equipment which has been manufactured or approved by Tractive AB.

Getting started

Preparations before commencing work.

Certain preparations must be done before starting work.

Cleaning: The machine should be carefully cleaned and all functions checked and are found normal before use of the machine.

Tools: Use only those tools that are intended to be used to operate the machine: For the Pentrunder 6-12 HF a special 3/8" – 8 mm socket is required.

Any 3/8" ratchet can be used that is not thicker than 54 mm (socket included). We offer a ratchet with Part No 65300200 Ratchet 3/8" 6 - 12 HF. You'll also need 65353800 Allen socket 3/8" 8mm 6 - 12HF. There is also the toolkit which suits all the Pentrunder machines and consists of the following: Ratchet 1/2" Kamasa, Socket 1/2" - 19 mm, Allen socket 1/2" 8mm x 90 and T-key 8mm x 100.



A torque wrench is needed for tightening the centre bolt on the blade flange and for tightening the clamp screw that clamps the blade flange to the machine.

Quick disconnects: Check the HF motor quick disconnect coupling for correct function and cleanliness. Grease coupling screw threads once per week.

Guide rollers: Check that the guide rollers on the saw head can move freely without too much friction. A certain amount of friction is always present as the bearings are double sealed with both rubber and steel scraper seals. Replace bearings and shields when worn or if rollers don't run freely.

Remote Control unit: Check the remote control unit for correct function and that the Cannon connector is clean and undamaged.

Water feed: Check that the machine can be supplied with clean cold water, minimum 4 L / minute (1 GPM).

Power cords: Check that all cords are undamaged and in faultless condition.

Power supply: Check if sufficient power is available on the site. The machine must be connected to a 380 – 480 V 3-phase supply with minimum 16 Amp fuses. We recommend to use a 40 Amp fuse if possible. With 16 Amp fuse the power output must be reduced by turning the feed rate knob on the remote control.

Water seal on saw head:

In the saw arm, there is a rotating shaft with seals used to feed the water into the centre of the spindle and further to both sides of the blade flange. Two seals seal off the water which is fed through the spindle, and further on through the blade flange to the blade. Just above the coupling clamp screw there is a small water drain hole.

Important! *If water comes out of the **Water Drain Hole**, (see the maintenance section for reference) while the water is switched on, this is an indication that the seals must be replaced. The seals should be checked every day and the oil in the arm should be checked once a week. If the seals are not replaced in time, water may enter the saw arm transmission and gearbox, which may cause the transmission to seize or cause irreparable damages.*

Please see the Maintenance section for instructions on how to replace the seals.

Safety precautions on the site:

Check with the foreman responsible that all necessary precautions have been performed before commencing work. Await the approval of the safety precautions and mounting position of the machine from a responsible person before work is commenced.

Warning! *If there is a possibility that cut concrete blocks may fall causing injury or damage to persons or property then they must be secured before starting work. The risk area must be roped off and a responsible person left in charge, in a safe place, to prevent entry of unauthorised persons.*

Preparation and mounting of track feet and tracks

Bolts for fastening: The track feet and the tracks should be mounted in such a way that they can not become detached when the machine is working, or at sudden changes in load on the anchor bolts.

Warning! If HKD anchors or other high quality expansion anchors cannot be fixed securely, the track feet must be securely fixed with through bolts and large washers to achieve the required level of safety.

Positioning of feet: The track feet should preferably be mounted in the position shown in the picture above. The distance from the edge of the feet to centre of cut is then 128 mm (5"). The distance from anchor bolt to centre of cut is 217 +/- 25 mm (8.54 +/- 1").

The track feet are designed to fit the track to the surface the machine will work on. The feet must be fixed by means of M12 x 50 (1/2" x 2") screws of 10.9 quality, or better, using a thick washer and anchors of type HKD M12 (1/2") or equivalent.

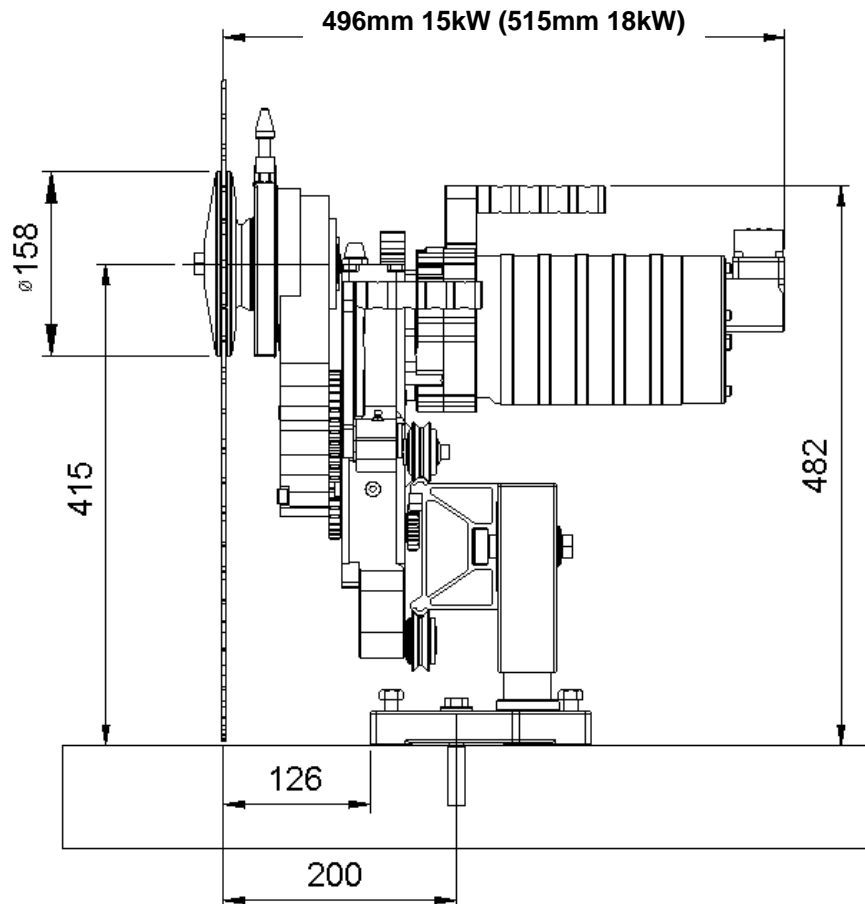

Alternative position of track feet:

In certain circumstances it is impossible to mount the track feet as shown in the picture below. If the track feet must be mounted differently, this may affect the stability of the track. If this is the case, more track feet should be fitted to spread the load and increase stability.

Adjusting the height of the track feet.

The height of the fork can be adjusted totally 12 mm by turning the fork CW or CCW, to compensate for irregularities on the wall. Please be sure that the fork is not threaded all the way out before the track is mounted. Leave at least ½ a turn or preferably 5 turns from the fully out or in position.

Mounting the track:

The track is mounted using clamp screws which fit into the fork of the track foot. At least two feet must be used to mount one track and the distance between the track feet should not be more than 2 meters (6.5ft). When bigger blades than 1200 mm (48") are used, we recommend setting the track feet closer than 2 meters (6.5ft).

The clamp screws are fitted in T-slot clamps running in T-slots at the rear of the tracks. These T-slot clamps can be locked in any position by means of a knurled knob.

A clamp screw is fitted in to the fork and should be tightened to 50 Nm (fairly hard) with a 19 mm (3/4") spanner.

Important! Be sure to check that the fork is aligned with the track and that there is no gap which can cause the track to be warped, the cut to be uneven and the feed regulation to be bad.

Warning! Be careful to position the clamp screw in the countersink of the yoke on the

Joining two or more tracks together:

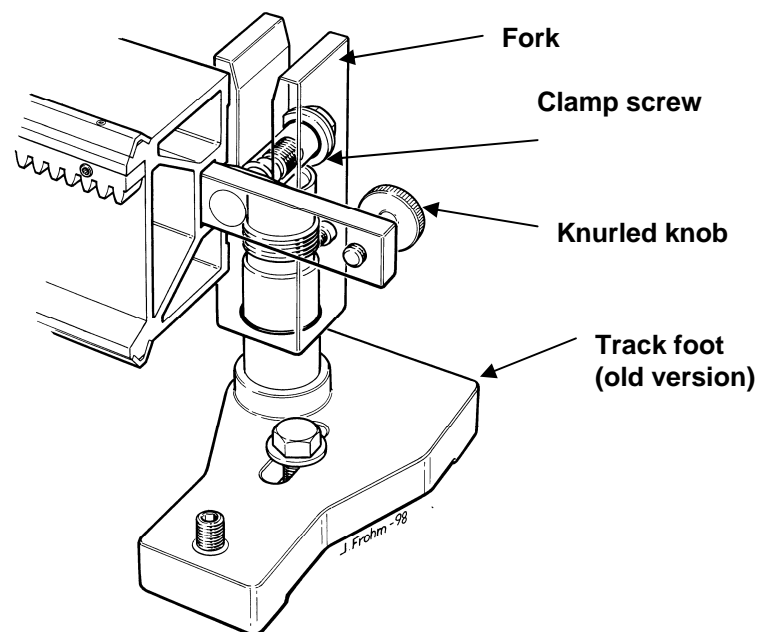

If tracks are to be joined when making long cuts the yoke of the mounting foot should be positioned centrally under the joint. True up the tracks carefully sideways using a spirit level or a straightedge.

Using Joint Blocks

When using Joint Blocks a track foot should be used within 60 cm (2 ft) of the Joint Block.

Important! Joint Blocks are for connecting two tracks together and are not designed to handle the full load of the saw when cutting, therefore one track foot must be mounted within 60 cm (2 ft) of all Joint Blocks).

Mounting the saw head on the track

The saw head runs on the track on four conical rollers. The upper rollers are fitted on eccentric shafts, opened and locked by turning the handles. Fold the saw onto the track, the lower “eccentric” rollers engaged first. Move the saw head slightly along the track to engage the travel gear with the rack, then fold the saw completely on to the track, press the locking pins and turn the handles until the locking buttons pops up again.

Warning! Before the saw is operated, always check that the eccentrics are locked in position to prevent the saw from falling off the track. Do not turn the handles unless the locking pins are released.

Warning! Always check that the handles are locked before starting to cut.

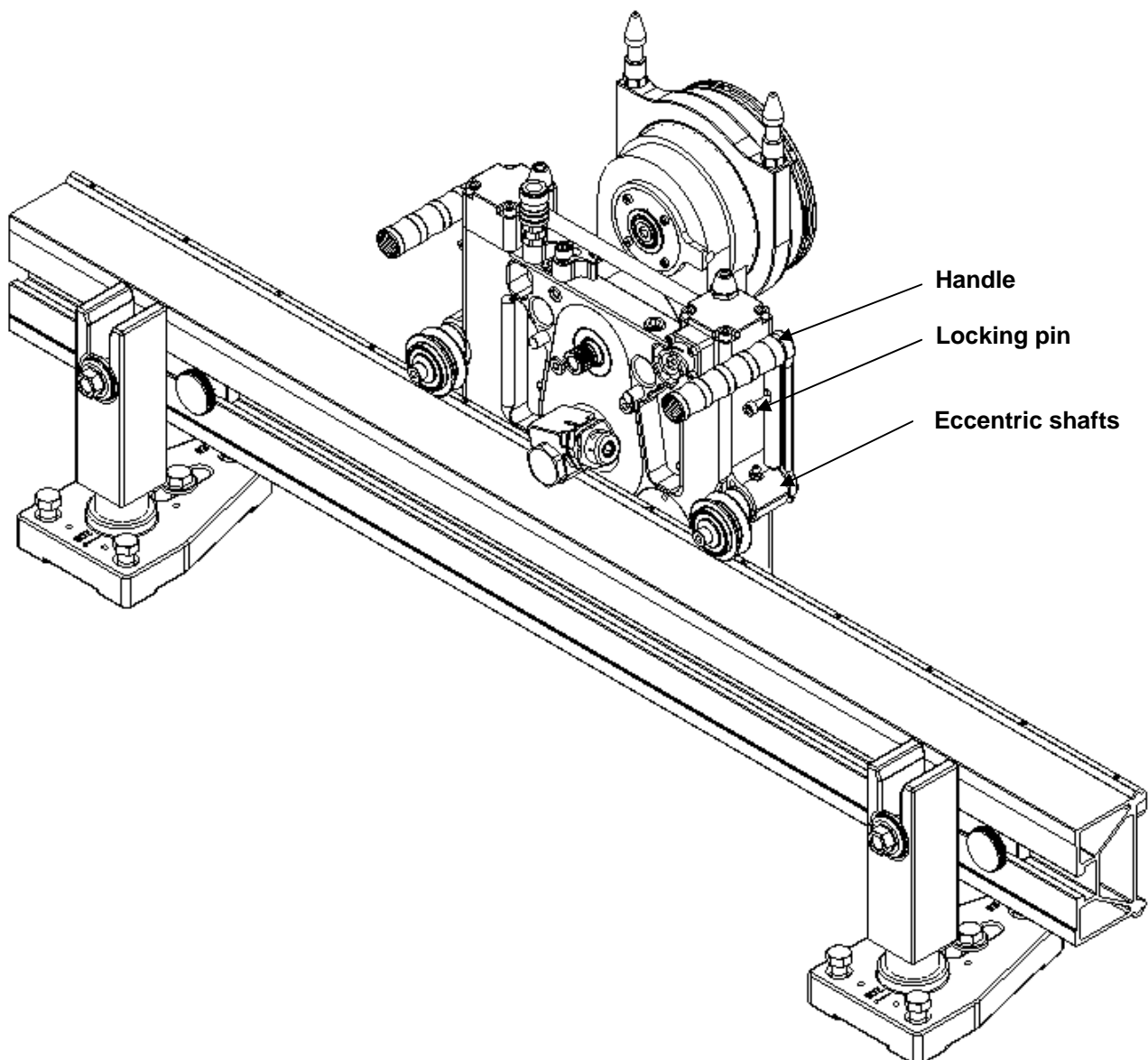

Quick disconnect coupling for HF-motor on saw head

To reduce the weight of the parts that must be handled by the operator, the saw head is basically divided in the saw head unit and the drive motor.

The HF-motor is easily fitted on the saw head with a simple and reliable quick coupling. Two clamp screws hold the HF-motor securely in place while the machine is working. To fit the HF-motor, align the splined drive shaft and clamp studs with the holes in the saw head, rotate the saw blade very slowly by hand until the splines fits and motor seats properly. Then tighten the clamp screws using the 8 mm Allen T-key.

To remove the HF-motor, turn the clamp screws three (3) full turns CCW and pull the motor straight out from the saw head.

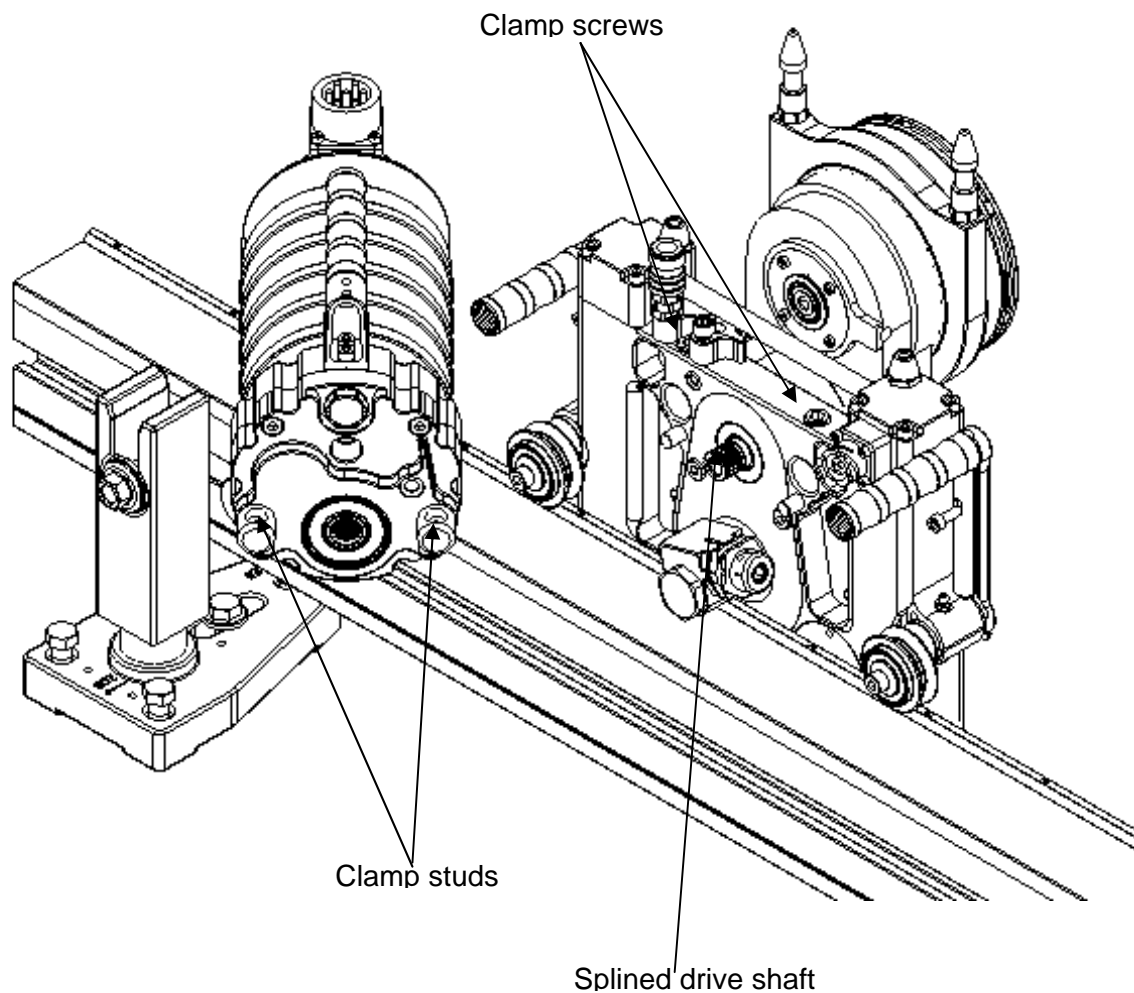

Warning! To avoid any possibility of injuries as a consequence of an unintentionally started HF-motor, the power cord between the Pentpak and the HF-motor **must be disconnected** when the HF-motor is fitted to or removed from the saw head.

Quick disconnect coupling for the saw blade

Function principle:

The saw blade is fitted on a blade flange by means of an outer collar and clamped by means of a special centre screw, or, for flush cutting, on a special flush cutting flange by means of 6 countersunk screws and nuts.

The blade flange, regardless of type, is provided with a radial T-slot to the centre of the flange. The flange, with blade fitted, is mounted on the machine spindle and its pull stud which fits in to the T-slot in the flange. When the coupling is tightened with the locking screw at the rear of the spindle, the flange is clamped towards the machine spindle by the pull stud which then moves inwards.

The flange and the spindle are provided with drive dogs to transmit the torque to the blade. The dogs must always be aligned, in mesh, for the coupling to work properly.

At the same time as the pull stud moves inwards, a conical centering ring moves outwards to centre the flange on the spindle. This ring at the same time interlocks the coupling by blocking the T-slot. This principle is very safe, as it does not require more than one single operation to be carried out to clamp and interlock the coupling. Even if the coupling is not completely tightened the saw blade can not fall off the spindle as the conical ring keep the blade on the spindle. It is however very important that the dogs are completely in mesh before the coupling is tightened.

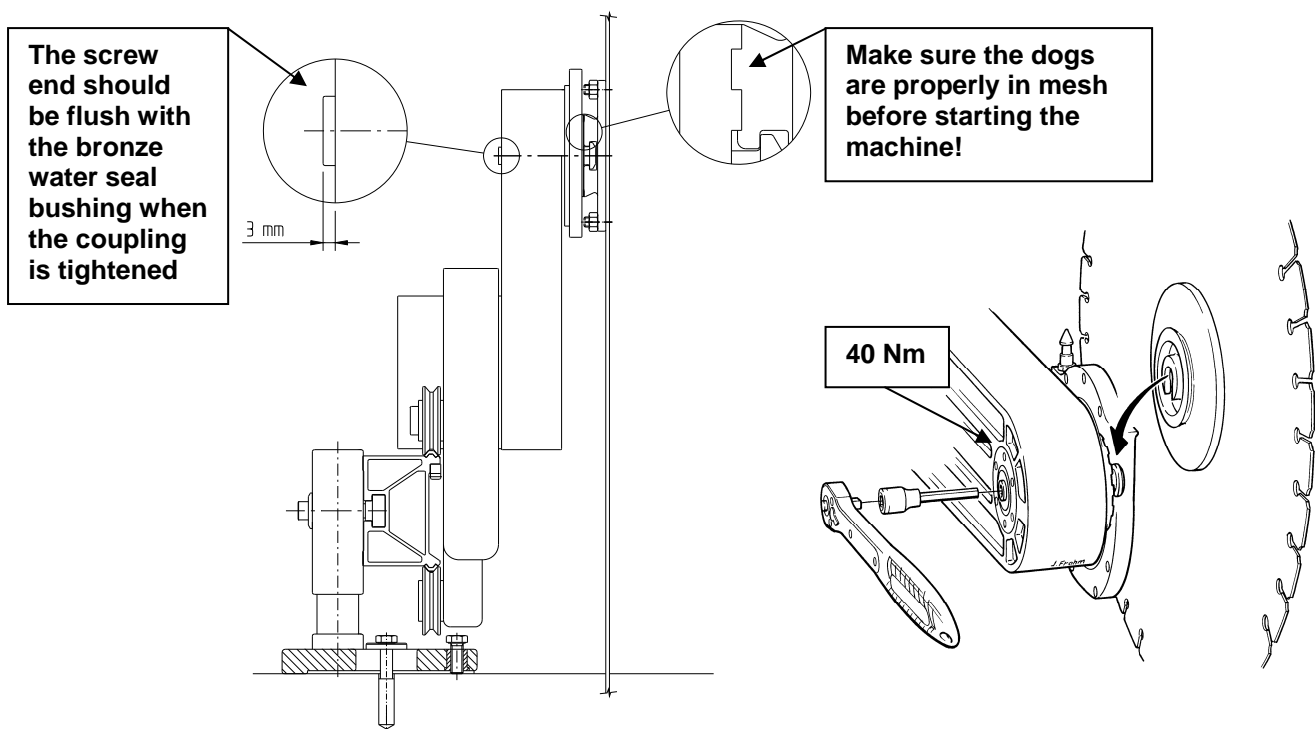

Warning! Never fit the blade and flange to the saw spindle before first disconnecting two orange colored power cords from the saw. This important rule must always be strictly followed to ensure that the blade motor or movements of the machine cannot be unintentionally started. Failure to follow this instruction may result in serious personal injury or death.

The power pack can be placed out of sight of the operator, or on a different level, and the only way to protect the operator from accidental starting of the blade motor is for the operator to always disconnect the two orange colour power cords. With the orange colour cords disconnected no power can go to the saw head.

Warning! The drive dogs on the machine spindle and blade flange must be completely in mesh before the clamping screw is tightened to prevent damage to the coupling. Failure to follow this instruction may result in coupling overload and a failure can lead to serious personal injury or death.

How to fit a blade on a standard blade flange:

Centre bore: The saw blade should have a hole with diameter 60 mm $-0 +0.1$ mm, and be free from cracks, dents, burrs and dirt.

Transmission of torque: The friction surfaces of both the flange and the blade must be free from grease and dirt to be able to securely transmit the torque of the saw blade motor without slippage. Slippage will cause irreparable damage to the flanges.

Clamping: The blade is fitted on the inner flange and is clamped by the outer collar with a special centre bolt. Grease the centre bolt and thread regularly.

The centre screw should be tightened to 60-70 Nm for the version with two friction surfaces and 40 Nm for the version with one friction surface, see picture below for difference. Don't mix the different versions.

The blade and flange are now ready to be fitted on to the machine spindle with the quick coupling, see "Mounting the blade with flange on the machine spindle".

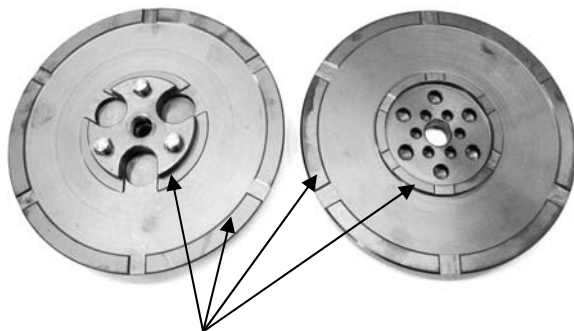

Two friction surfaces:
Tighten with torque wrench to 60-70 Nm
Must be kept clean!

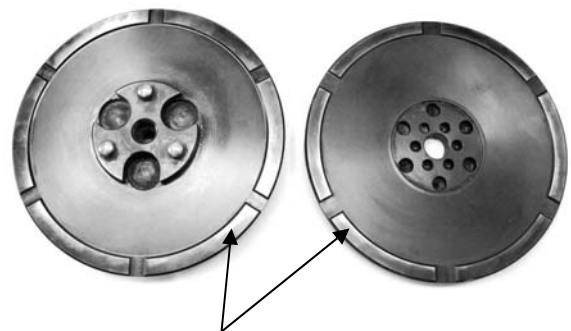

One friction surface:
Tighten with torque wrench to 40 Nm
Must be kept clean!

Warning! The bolt or the female thread in the blade flange may never start to corrode. Corrosion of the threads or any part of the bolt may cause failure of the bolt which can lead to serious personal injury or death.

Warning! The saw blade must always be fitted correctly and a torque wrench must be used to tighten the centre bolt to the correct Nm, to avoid danger. The instructions given above must always be followed to avoid faulty mounting of the blade.

How to fit a blade on a flush cutting flange:

The Pentrunder 6-12HF is a powerful machine. This means the blades which are fitted for flush cutting must be properly fixed to the machine. When a blade is fitted to a flush cutting flange, it is very important for safety to respect the following instructions:

- Centre bore:** The saw blade should have a hole with diameter 60 mm $-0 +0.1$ mm, and be free from cracks, dents, burrs and dirt.
- Clamping:** The blade is fixed with 6 countersunk screws. The bolt circle and size varies depending on market and supplier of the blade.
- Bolt circle:** In Europe 110 and 130 mm bolt circle is commonly used with either M10 or M8 screws.
- Screw quality and torquing of screws:** The blade must be clamped with countersunk screws from Unbrako and be of quality 10.9. The nuts must be of type "Nyloc" and the fasteners must be torqued with a torque wrench to 35 Nm for M8 screws and to 50 Nm for M10 and 3/8" screws. The threads must be lubricated with grease or oil.

Warning! *The saw blade must always be fitted correctly to avoid danger. The instructions given above must always be followed to avoid faulty mounting of the blade, which in turn can cause serious personal injury or death.*

Warning! *It is important to be aware of the fact that when a flush cutting blade is used, the blade is clamped merely by the six countersunk screws, nothing else.*

Warning! *Flush cutting is a questionable method from a safety point of view. As flush cutting requires use of a "half" blade guard, the operator should be aware that the level of safety never can be comparable to normal cutting when a full blade guard is used. This is a potentially dangerous method and should be treated likewise.*

Important! *The blade must have a bolt circle where the holes are spaced on an even and exact pitch to prevent unequal load distribution on the screws, blade and flange. Look out for cracks around the counter sunk holes in the blade. Some blades are prone to crack and if that happens, it is potentially a very dangerous situation which can lead to fatal accidents.*

Mounting the blade with flange on the machine spindle

If the procedure described above is followed, the blade and flange are now ready to be fitted on to the machine spindle with the quick coupling. The blade flange is provided with a radial T-slot to the centre of the flange. On the opposite side of the T-slot, there is a groove and this groove should be positioned upwards when the blade flange is mounted on the saw head spindle.

Use a $\frac{1}{2}$ " torque wrench to tighten the clamp bolt on the rear side of the spindle. Tighten to about 40 Nm. Do not over tighten the coupling clamp screw!

Warning! Always keep all part of the coupling clean! The safe operation of the coupling depends on cleanliness of all coupling parts on the machine, and the blade flange!

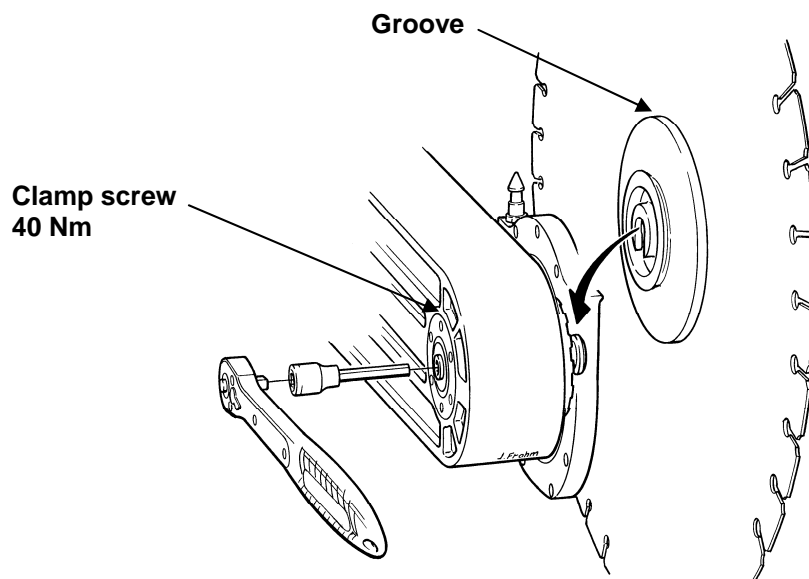

Peripheral cutting speed and spindle speed

There are two principal reasons for the peripheral cutting speed to be adjusted:

- The blades are of different diameter for different requirements on cutting depth. The peripheral cutting speed should be approximately the same regardless of diameter. A larger diameter blade will rotate at a lower speed than a small one and vice versa for the same peripheral speed.
- Concrete can be very different depending on the aggregates used, how much steel reinforcement is used etc. Therefore it can be necessary to adapt the peripheral cutting speed to the quality of the concrete, all depending on the type, performance and condition of the saw blade. A rule of thumb is that harder concrete and/or high content of steel is more easily cut with lower speeds than normal concrete, and vice versa.

The Pentruder 6-12HF is equipped with a 2-speed gearbox to give optimum power for different conditions and size of blade. In combination with alteration of the frequency from the power pack a useful speed range from approximately 550 to 1200 RPM is available.

Warning! *The peripheral cutting speed may not exceed approximately 56 metres / second as this can cause the blade to fail. In the worst case segments can come loose and be thrown with high velocity. For very hard aggregate the peripheral cutting speed should not exceed 30 metres /second.*

Warning! *If the wrong gear and potentiometer setting is used the blade can rotate with a too high peripheral speed, which can cause the blade to fail and lead to fatal injury.*

How to choose correct gear and cutting speed

Depending on what size of blade you are using, you achieve a suitable peripheral cutting speed by choosing the correct gear, see the tables below. Suitable cutting speed is normally between 40 and 55 metres per second. For special conditions like concrete with very hard aggregate and/or high content of steel the cutting speed should usually be lower.

You can also use the potentiometer for blade speed control to adjust the speed continuously within the range of each gear (alteration of the frequency - Hz to the motor).

Pentruder 6-12HF with 15 / 18 kW HF-motor

Peripheral cutting speed and spindle speed in metres / second for different blade diameters, @ 350Hz: (Set potentiometer at 80% on the remote control)

Gear	Ø 600	Ø 700	Ø 800	Ø 900	Ø 1000	Ø 1200
1 = 640 rpm	20.2	23.5	26.9	30.2	33.6	40.3
2 = 940 rpm	30.0	35.1	40.1	45.1	Not permitted	Not permitted

Pentruder 6-12HF with 15 / 18 kW HF-motor and potentiometer setting at 80%.

Peripheral cutting speed and spindle speed in metres / second for different blade diameters, @ 400Hz: (Set potentiometer at 90% on the remote control)

Gear	Ø 600	Ø 700	Ø 800	Ø 900	Ø 1000	Ø 1200
1 = 720 rpm	22.7	26.5	30.2	34.0	37.8	45.4
2 = 1075 rpm	33.8	39.4	45.1	50.7	Not permitted	Not permitted

Pentruder 6-12HF with 15 / 18 kW HF-motor and potentiometer setting at 90%.

Peripheral cutting speed and spindle speed in metres / second for different blade diameters, @ 440Hz: (Set potentiometer at 100% on the remote control)

Gear	Ø 600	Ø 700	Ø 800	Ø 900	Ø 1000	Ø 1200
1 = 800 rpm	25,2	29,4	33,6	37,8	42,0	50,4
2 = 1200 rpm	37,6	43,8	50,1	Not permitted	Not permitted	Not permitted

Pentruder 6-12HF with 15 / 18 kW HF-motor and potentiometer setting at 90%.

Warning! The gear selection knob may not be operated before first disconnecting the two power cords from the saw. This important rule must always be strictly followed to ensure that the blade motor cannot be started unintentionally. Failure to follow this instruction may result in serious personal injury or death.

The power pack can be placed out of sight of the operator, out of reach for the operator, or on a different level, and the only way to protect the operator from accidental starting of the blade motor is for the operator to always disconnect the two power cords. With the power cords disconnected no power can go to the saw head.

Warning! The peripheral cutting speed may not exceed approximately 56 metres / second as this can cause the blade to fail. In the worst case segments can come loose and be thrown with high velocity.

Warning! If the wrong gear and potentiometer setting is used the blade can rotate with a too high peripheral speed, which can cause the blade to fail and lead to fatal injury.

How to shift gears in the 2-speed gearbox:

- Gears may only be shifted when the power cord is disconnected from the HF-motor. The gear selection knob is placed below the HF-motor.
- On the Gear Shift Knob, two positions are indicated: **1** for low speed, and **2** for high speed. There is a reference mark in the housing, in the form of a groove.
- To shift gear, if the gear is in position **1**, push in the gear shift knob, turn the blade slightly while turning the knob **CCW** to position **2** which is the fast speed. Even if there is a hex-hole, avoid using tools to shift gears.
- To shift gear, if the gear is in position **2**, push in the shift knob, turn the blade slightly while turning the knob **CW** to position **1**, which is the low speed.

Important! The 2-speed gearbox will be seriously damaged if the gear selection knob is in an incorrect position.

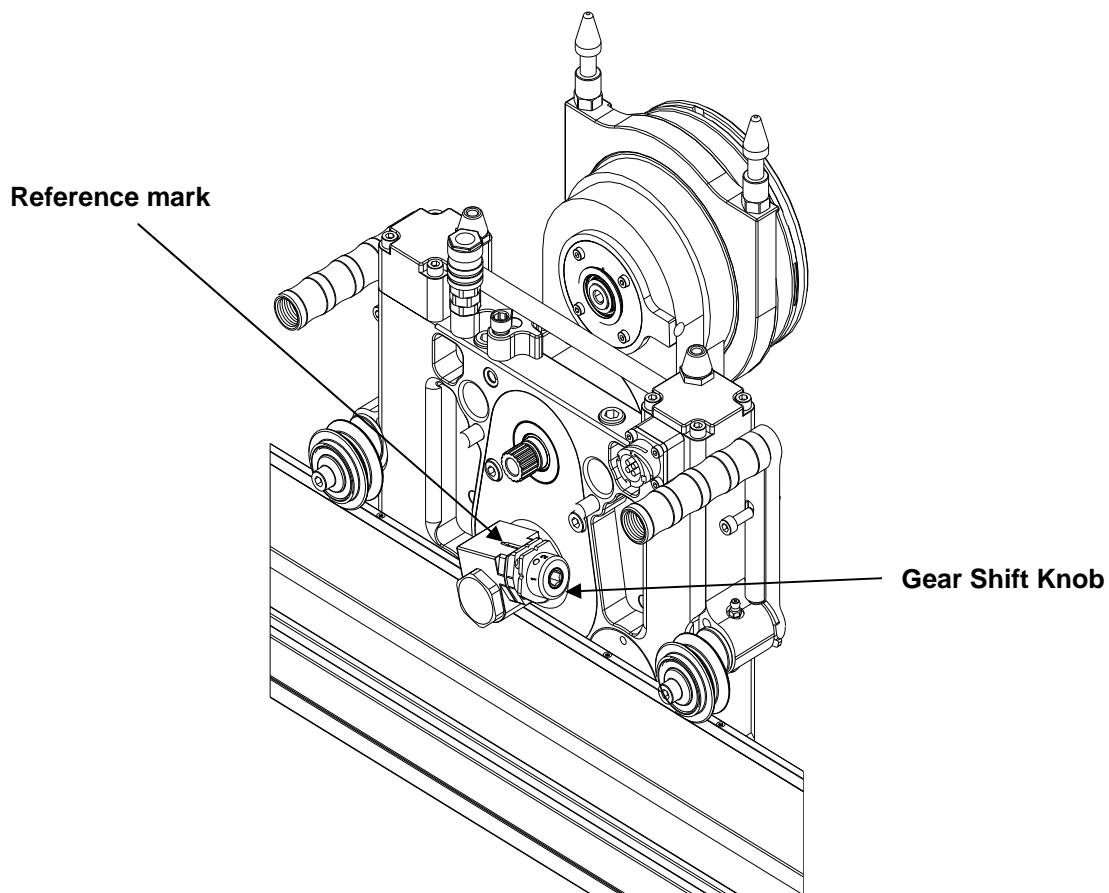

Mounting the blade guard

New safety regulations means that greater emphasis has to be put on safety, and therefore on the blade guards, and these can now, thanks to a new and better design, remain on the machine at all times. A prerequisite to achieve any level of protection is that the guard is fitted to the machine at all times. For the 6-12HF the guards are available in three different sizes, Ø 800 (32"), Ø 1000 (40"), and Ø 1200 (48") for normal and flush cutting. Fully covering "parallel" blade guards are also available for use together with a parallel blade guard guide.

The blade guard is automatically controlled by the movements of the saw arm, and the operator does not have to adjust the guard while the machine is running. The guards consist of three main pieces, a middle main piece and two detachable side pieces. A pivoting shield is provided to contain overspray from the blade. It should be adjusted before starting to cut.

The guard is mounted by entering the grooved bushing into the C-profile on the guard and then pushing the T-bar with the two holes in it on to the two tapered bolts on the saw arm. Then the safety lock is slid down and secured with an 8 mm (5/16") Allen key. To remove the guard, first remove the safety lock and press the two locking screws on the guard together and take off the guard.

Warning! The blade guard has many functions. The most important one is to protect the operator and other persons from accidental injury. In a situation when, for example, the operator or someone else accidentally falls against the machine, the guard is there to as well as possible protect against contact with the running blade. In other potentially dangerous situations, for example if a cracked or faulty blade is used, or if the blade is not properly fitted, or the quick release coupling is improperly used, the guard is there to reduce the damage done by a blade.

The blade guard must be mounted at all times when the blade is rotating under power. The instructions above must always be

followed. Failure to follow this instruction may result in serious personal injury or death.

Warning! The blade guard may not be fitted or removed before the two power cords are disconnected from the saw. This rule must always be followed to eliminate that the blade motor is started by accident or the arm or chassis moved when the operator is working on the saw head. Failure to follow this instruction may result in serious personal injury or death.

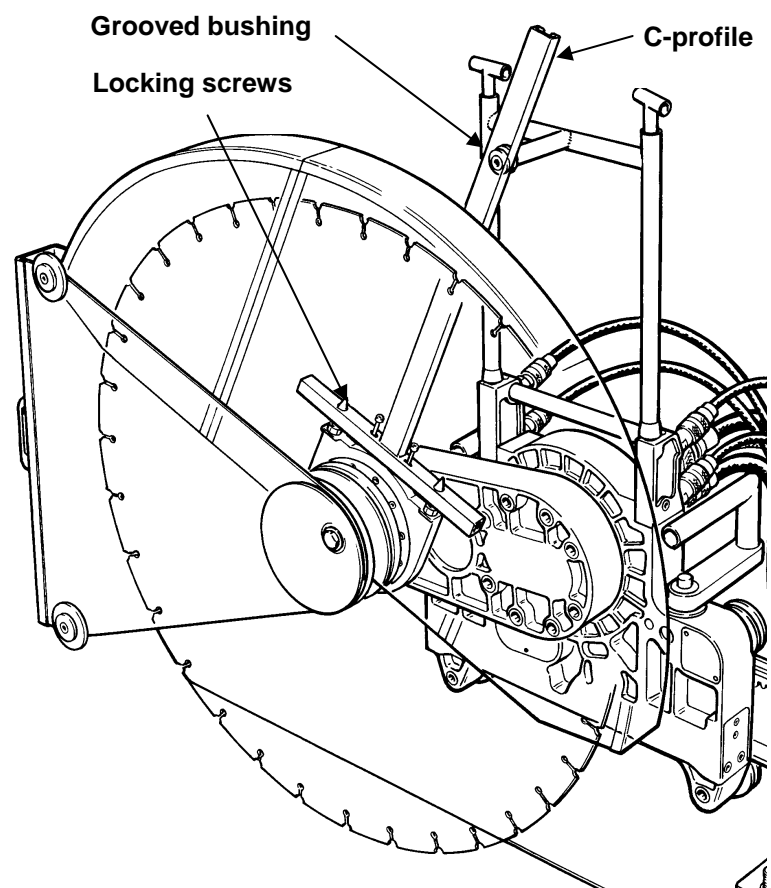

Preparing the power pack

Positioning: The power pack should be positioned away from where the sawing takes place **and should be kept dry at all times**. It should preferably be placed on a flat surface.

Do **NOT** leave the power pack outside in the rain. The unit is ventilated but to prevent possible damage to electronic components we recommend that it is kept dry to prevent excessive condensation forming.

Power connections: Electric power to the blade motor is supplied by one 18 mm diameter orange colour 9 m (30 ft) cord. The feed and travel motors are supplied by one smaller diameter orange colour 9 m (30 ft) cord packaged together with a 10 mm water hose. The water quick disconnect coupling with a 90° elbow should be at the saw head end.

Warning! *The power pack should not be connected to the electrical supply until all power cords are first connected to the saw and power pack.*

Connection to water supply:

The power pack is water cooled and needs a minimum of 4 litres (1 gallon) of cool water per minute at full power output. The water pressure should be at least 1 bar (15 PSI) and maximum 5 bar (72.5 PSI). The water supply may only be connected to the short hose on the power pack water valve.

Important! *In sub zero temperatures the remaining water inside the power pack cooling circuit must be blown out with compressed air. The power must be switched ON, the water valve must be switched ON, the water couplings must be disconnected, and then the water can be blown out using compressed air. Alternatively, if no electric power is available, blow backwards with compressed air in the coupling going to the saw head. The check valve in the water ON/OFF-valve will then open and the remaining water in the power pack can then be blown out.*

Leaving water in the power pack in sub zero temperatures will destroy components in the power pack and potentially cause a complete failure of all electronic equipment inside the box.



In sub zero temperatures, and if electrical power to the unit is not available, blow with compressed air in this coupling to remove water from the heat sink and tubing inside the power pack.

Connecting to remote control:

The power pack may be disconnected from the mains when the remote control is connected. The multi pin connector must be in the correct position with the notch pointing upwards for the clamping ring to close.

Power supply:

The power pack must be connected to a 5-pin 380 - 480 V 3-phase supply with minimum 16 Amp fuses. We recommend to use a 40 Amp fuse if possible. With 16 Amp fuse the power output must be reduced by turning the feed rate knob on the remote control. A neutral is NOT needed other than for the 230V single phase supply.

Connecting to mains:

The power pack is equipped with a 32 Amp receptacle. To use other sizes than 32 Amp plugs an adaptor must be fitted.

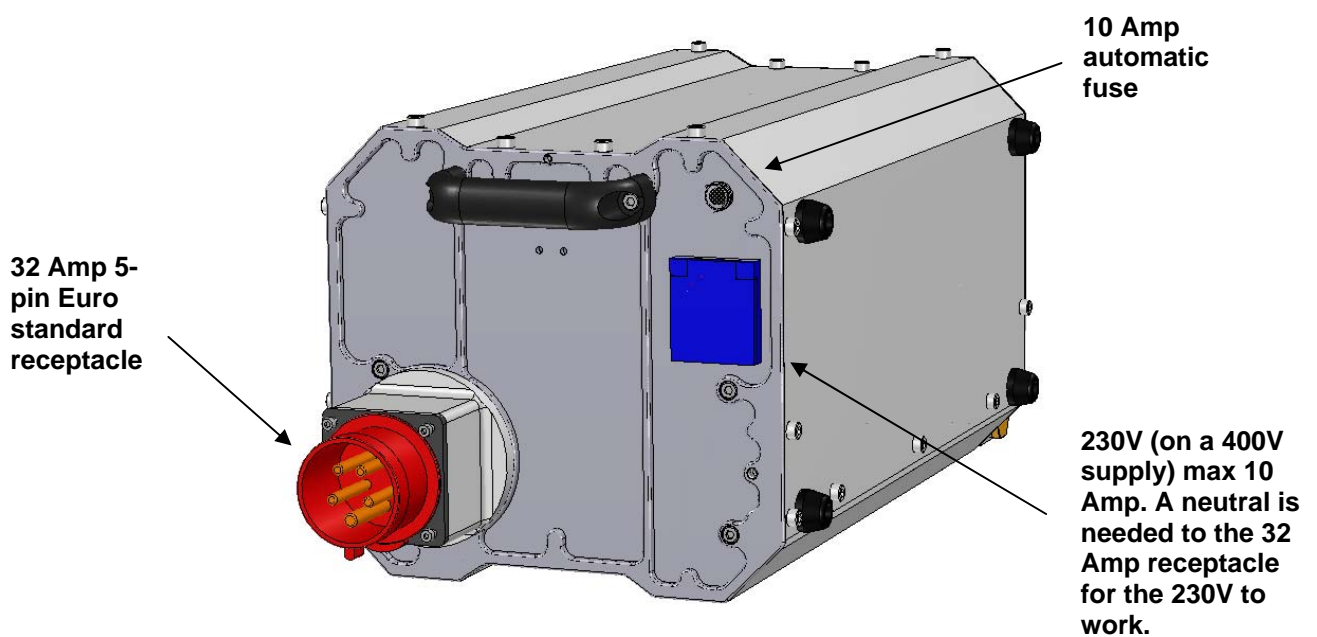

Starting the power pack:

Connect all cords, big diameter orange colour cord to HF-motor, small diameter orange colour cord to feed and travel motors, grey remote control cord to the power pack and lastly a 380 – 480V 3-phase cord to the mains. Then press the green push button. A green light in the button should then come on.

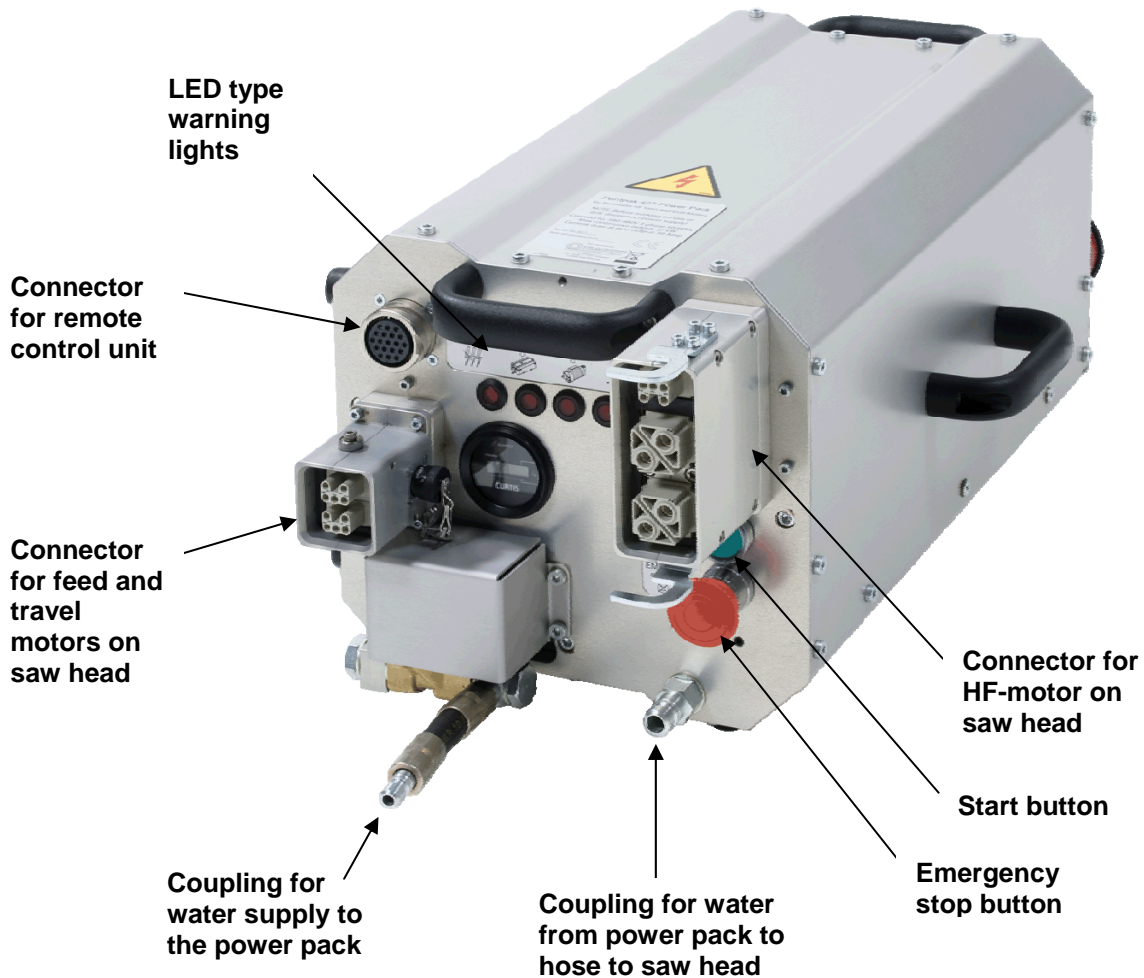

LED type warning lights on the power pack

There are four red warning LED:s on the Pentpak. Below is an explanation of the respective functions.

LED for indication of loss of one or more phases

One blink:



Loss of phase on mains. Loss of one power supply phase line can be caused by a blown fuse, faulty cords, faulty plugs or receptacles, or other problems. If the light is on, check fuses, input voltage, cords etc.

Two blinks:

Too low incoming voltage. Can be caused by too long and/or small extension cables. Check voltage, connectors, cords and generator if applicable.

Three blinks:

Too high incoming voltage. Connect only to 3-phase 380 – 480V. Check voltage, connectors, cords and generator if applicable.

With one phase missing from the power supply, feeding may work, but the blade will not rotate.

General advice to eliminate any of the above fault conditions: Push the Emergency stop button. Eliminate the cause of the problem, i.e. replace blown fuses, repair cords, repair or replace plugs and receptacles.

Note: To allow capacitors in the inverter to discharge, at least one minute must elapse after the emergency stop button is pressed and the green start button is pressed.

LED indicating status for the power pack

One blink:



Overcurrent alarm. May occur if the blade is jammed in the cut, Press start blade switch to reset or unplug the unit for 60 seconds.

Two blinks:

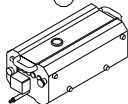

Unknown device connected to Pentpak. Software update needed in Pentpak.

Three blinks:

Other alarm for frequency inverter. Unplug the unit from the power supply, wait at least one minute and plug it in again. If the alarm has gone away you can proceed as normal. If the alarm doesn't go away, the unit must be checked by a technician trained on this equipment.

Four blinks:

Frequency inverter alarm. Must be checked by a technician trained on this equipment.

Quick blinks:

Temperature in the frequency inverter has risen to a too high level. Protect from direct sunlight, increase water flow.

Continuously on:

The Pentpak is shut off due to over temperature.

LED indicating status for the HF-motor

- 1) Pentpak is powered, but the green start button on the Pentpak button has not yet been pressed. A test is made for the can-bus to the HF-motor and the chassis.

One blink:

Short circuit in the digital communication system. The fault can be in the HF-motor, motor cable or inside the Pentpak.

- a) Disconnect motor cable from Pentpak. If the alarm disappears, go on to b). If the alarm remains the same the Pentpak is faulty.
- b) Connect motor cable to Pentpak and disconnect HF-motor. If the alarm disappears, go on to c). If the alarm appears when connecting, the cable is faulty.
- c) Connect motor cable to Pentpak and HF-motor. If the alarm appears when connecting, the connector on the HF-motor is faulty.

- 2) Pentpak is powered, and the green start button on the Pentpak button has been pressed.

One blink:



The HF-motor chassis-ID is wrong. Nothing is broken, but the HF-motor is incompatible with the Pentpak or the machine. Pentpak software update needed.

Two blinks:

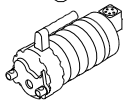

HF-motor temperature sensor in windings is not working correctly.

Three blinks:

HF-motor or motor cable is not working correctly. Short or open circuit.

Quick blinks:

HF-motor temperature is high, output power is automatically reduced. Increase water flow.

Continuously on:

HF-motor has been shut off due to over temperature. This can also indicate that no HF-motor is connected or that the power pack doesn't find a motor, e.g. damaged motor-ID chip or motor cable.

Important!: *The motor will be switched off automatically when the motor winding temperature is over 140°C (284°F). The coolant water should then be left running through the power pack and HF motor to avoid terminal overheating. If the water is turned off after the motor has been switched off automatically, and when the warning light is on, terminal damage to the motor windings may occur.*

Note: *The outside temperature of the motor is no indication of the inside temperature of the motor. The temperature sensor is placed inside the motor windings and does not monitor the outside temperature of the motor. The windings can be working at a high temperature even if the motor is cold on the outside.*

Note: *The warning light will be off when the temperature has gone down to a temperature below 110°C. The motor cannot be restarted until the warning light goes off.*

LED indicating status for the feed and travel drive system

- 1) Pentpak is powered, but the green start button on the Pentpak button has not yet been pressed. A test is made for the can-bus to the HF-motor and the chassis.

Three blinks:

Short circuit in the digital communication system. The fault can be in the saw head, 24V cable or inside the Pentpak.

- a) Disconnect 24V cable from Pentpak. If the alarm disappears, go on to b). If the alarm remains the same the Pentpak is faulty.
- b) Connect 24V cable to Pentpak and disconnect saw head. If the alarm disappears, go on to c).
If the alarm appears when connecting, the cable is faulty.
- c) Connect 24V cable to Pentpak and saw head. If the alarm appears when connecting, the connector on the saw head is faulty.

- 2) Pentpak is powered, and the green start button on the Pentpak button has been pressed.

One blink:



Short circuit in the feed cable, saw head or any of the feed motors.

Two blinks:



24V under voltage alarm. The voltage has dropped below 18V.

Three blinks:

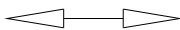

Automatic identification of machine type not working correctly. The chassis-ID is wrong. Nothing is broken, but the HF-motor is incompatible with the Pentpak or the machine. Software update needed in Pentpak.

Four blinks:

No digital servo found. Digital servo is defective.

Continuously on:

The digital servo has shut off due to over temperature. Push the emergency stop button to reset.

This can also indicate that no saw head is connected or that the power pack doesn't find the saw head, e.g. damaged chassis-ID chip or 24V cable.

To reset the alarm, press the emergency stop button and wait until the alarm lamp goes out. Then press the green start button to start the power pack again.

Remote control unit

The remote control unit is connected to the power pack through a Cannon connector. It is not possible to control any functions on the power pack unless the remote control is connected to the power pack.

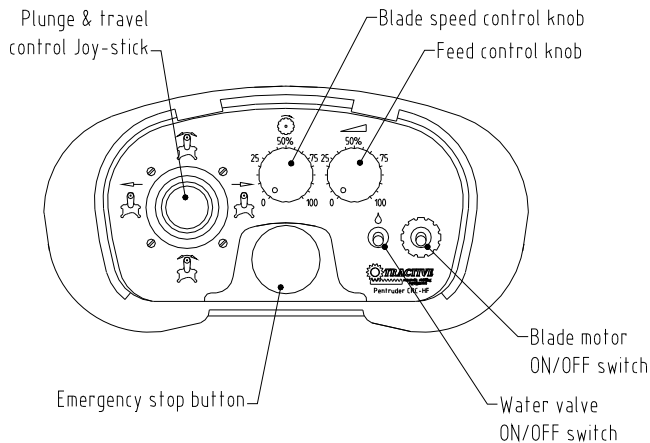

Available functions:

Switch for Blade Motor ON/OFF:

First push forward and hold the switch for Water ON/OFF and then, within 5 seconds, push the Blade ON/OFF switch forward to start the blade. The blade will start rotating slowly CW (clock wise) seen from the blade side, the “normal direction of rotation”. Turn up the rpm by turning the blade speed control knob. As soon as you turn up the potentiometer for blade speed control, it will rev up to 70% of maximum rpm. Use the potentiometer for blade speed control to set the desired rpm of the blade.

To stop the blade, push the Blade ON/OFF switch forward once again.

Warning! Torque wrench must be used for tightening the centre screw on the blade flange, the torque setting should be: 60-70 Nm for the flange with two friction surfaces and 40 Nm for the flange with one friction surface.

Warning! Torque wrench must be used for tightening the clamp screw that clamps the blade flange to the machine, the torque setting should be: 40 Nm

Switch for water valve: Move the switch forward to start and stop the water flow through the machine. The water flow will be switched on automatically when the blade is started. The water will be left running when the blade motor is stopped and the water must be switched off manually.

Potentiometer for blade speed control:

The minimum speed is set at 70% of the maximum speed. Full power is available when the potentiometer knob is between 85 % and 100 % on the potentiometer scale. At its maximum CW position, i.e. 100%, the motor power output is slightly reduced, by approximately 0.4 kW.

Potentiometer for feed and power regulation:

As long as the blade is spinning in the air, the potentiometer is used only to control rapid feed of the machine. From the moment the blade touches the concrete and a preset amperage draw is exceeded, the potentiometer changes its function and is then used to control the power used to drive the blade.

Between 80 - 100% the system will always try to reach maximum power. At 100 % the feed regulation is more aggressive than at 90 or 80%, but the machine will always try to reach maximum power also at the 80% or 90% setting. If the potentiometer is turned below 80% the power output will be reduced correspondingly.

Joystick for control of the movement of the saw head and radial arm:

Flick the joystick up or down to rotate the radial arm. Flick the joystick left or right to move the saw head along the track.

In case of a jammed Blade:

The power pack has an automatic function for resetting the frequency inverter if the blade is jammed. Move the blade out of the cut, or at least to a position where it can be started without too much resistance, and press the blade ON/OFF switch forward once, then it takes approx 15 seconds for it to reset. Certain reset procedures are activated depending on how sudden the stop was.

If the blade is jammed very, very abrupt, the reset procedure might not be enough. In this case you need to unplug the unit from the power supply, wait for 30 seconds and plug it in again.

NOTE: If one of the emergency stop buttons are pressed or the unit has been unplugged from the power supply, both the blade speed and the feed and travel potentiometer must be returned to zero before the machine is operational again.

Maintenance

For the Pentruder 6-12HF / Pentpak HF-power pack remain in a condition which is safe for operation at all times, certain maintenance is needed. Please read the instructions below carefully before any service work is commenced.

For safe and uninterrupted operation of the machine, we strongly recommend that the complete machine is brought back to your dealer for service for service and oil change at the stipulated oil change intervals or as agreed with your distributor. At this service the machine is checked for proper function and all components critical for safe and reliable operation are checked and replaced if necessary.

Please respect the following maintenance instructions:

Warning! No service or maintenance may be performed on the power pack unless it is disconnected electrically from the mains.

Warning! No service or maintenance may be performed on the saw head unless it is disconnected electrically from the power pack.

Bolts for flush cutting blades:

Always replace worn or damaged bolts with new of correct length and quality, M8 x 25 10.9 or M10 x 25 10.9.

Blade flange:

The threads on the centre screw and the female thread on the blade flange should be clean and well lubricated. The friction surfaces on the blade flange should be kept dry and clean.

Cleaning:

The machine should be carefully cleaned and all functions checked and found normal before use of the machine. If a high pressure cleaner is used, the nozzle may **NOT** be pointed at rotating parts on the machine. Avoid pointing at seals and electrical connectors.

Cables:

Check that all cables are in faultless condition.

Track guide rollers:

Check that the track guide rollers on the saw head can move freely without too much friction. A certain amount of friction is always present as the bearings are double sealed with both rubber and steel scraper seals.

Oil change in the saw head 2-speed gearbox/

Arm transmission:

Check the condition of the oil every week. If it is grey it needs to be replaced. This is an indication that the water seal needs to be replaced, see below "Water seal".

Change oil every 80 hours of operation.

Important! Before attempting to change oil, clean thoroughly around the plug and blow with compressed air before the plug is removed. If dirt is allowed to enter the gearbox, the gearbox may seize and any warranty is void. To change oil, unscrew the oil-plug and drain the arm completely. Refill with 180 ml (6 ounce) of Omega 690 gearbox oil. Clean the magnetic plug, fit it and tighten again.

Oil change in the travel and arm feed worm gear

transmission: This oil should be changed every 80 hours of operation when service is done to the machine. The travel worm gear transmission is filled with 60 ml and the arm feed worm gear transmission with 60 ml of Omega 680 oil.

Oil change in the slip clutch

Transmission housing: This oil change may only be carried out by a trained technician familiar with this machine. **Change oil every 80 hours of operation.**

***Important!** Before attempting to change oil, clean thoroughly around the oval cover and blow with compressed air before the cover is removed. If dirt is allowed to enter the gearbox, the gearbox may seize and any warranty is void. To change oil, remove the cover and drain the cavity completely. Refill with 0.14 L (0.148 quart) of gearbox oil Omega 690 (synthetic oil with 75W viscosity). The oil must meet GL5 specifications.*

Oil change in the HF-motor high

speed transmission: This oil change may only be carried out by a trained technician familiar with this machine. **Change oil every 80 hours of operation.**

***Important!** Before attempting to change oil, clean thoroughly around the plug and blow with compressed air before the plug is removed. If dirt is allowed to enter the gearbox, the gearbox may seize and any warranty is void.*

Unscrew the oil-plug and drain the gearbox completely. Refill with 0.235 L (0.248 quart) of **clean and preferably filtered** gearbox oil Mobil SHC 626 (synthetic oil with 75W viscosity). The oil must meet GL5 specifications. Clean the magnetic plug, fit it and tighten again.

Cooling housing at rear of HF-motor:

Fill with 85 ml of Mobil SHC 626 at service (every 80 hours of operation).

Overload clutch:

If any of the overload clutches have been overloaded or worn out, a trained mechanic can repair the coupling by replacing the clutch plates, but we recommend that the machine is brought to your dealer for service.

Digital communication connectors:

Check all connectors for proper function and replace when necessary. All parts in the connectors are available (except remote control connector). All wires can be re-installed with standard hand tools (except remote control connector).

Quick disconnect coupling for the saw blade:

The flange and the spindle are provided with drive dogs to transmit the torque to the blade and centering cone to align the flange to the spindle. Clean the dogs and the cone regularly to allow the flange to always be aligned and properly in mesh.

The centering cones in the spindle and flanges should be brushed with a brass brush on the outside and inside and be kept perfectly clean at all times. If they are not clean, the coupling may be damaged beyond repair and the blade may not run true.

Remote Control unit:

Check the remote control unit for correct function and that the connector is clean and undamaged.

Water seal on saw head:

In the saw arm, there is a swivel to feed the water into the centre of the spindle and further to both sides of the blade flange. Two seals seal off the water which is fed through the spindle quick disconnect screw, and on through the pull stud at the front of the spindle. Beside the screw there is a small hole. (see picture on next page for reference)

Important! *If water comes out of that hole while the water is switched on, this is an indication that the seals must be replaced. Please contact your dealer for service. The swivel should be checked every day. If the seals are not replaced in time, water may enter the saw arm transmission and gearbox, which may cause the transmission to seize or cause irreparable damages. Please take care to replace the seals every month.*

Procedure to replace water seals:

1. Use two screwdrivers to pry out the seal cartridge as shown in the picture below. The seal arrangement is shown in the bottom picture. Please note the wear sleeve on the rotating shaft.
2. Replace the worn seals with new ones and grease seals with a water resistant grease.
3. Use a plastic hammer to lightly tap the seal cartridge in place again.
4. If the wear sleeve needs to be replaced, the wear sleeve can be pulled off using a special tool, Part No. 65420100. The new wear sleeve should be installed flush with the clamp screw as shown in the picture below.

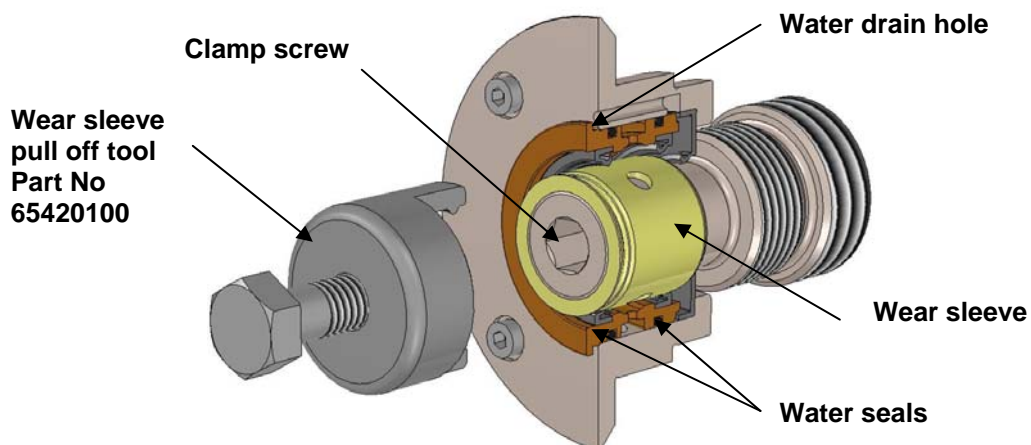
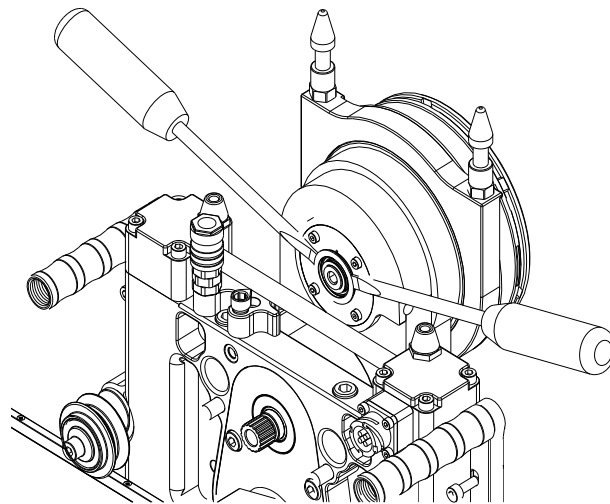

Service on the rotating blade guard flange:

The blade guard holding flange consists of a nylon flange bolted to the saw arm. Around the nylon flange there is an aluminium outer flange that rotates with the blade guard as the arm rotates.

The whole assembly must be disassembled, cleaned and greased regularly to function well.

1. Remove the blade flange from the spindle.
2. Remove the 16 M4 countersunk screws and remove the stainless steel ring.
3. Remove the 16 M4 Allen Screws and take off the flange.
4. Disassemble the various parts and clean in a solvent.
5. Grease all parts and replace worn O-rings. See spare parts manual for part numbers and sizes.
6. Assemble all parts and be sure O-rings are well covered in grease. Preferably use water resistant grease.

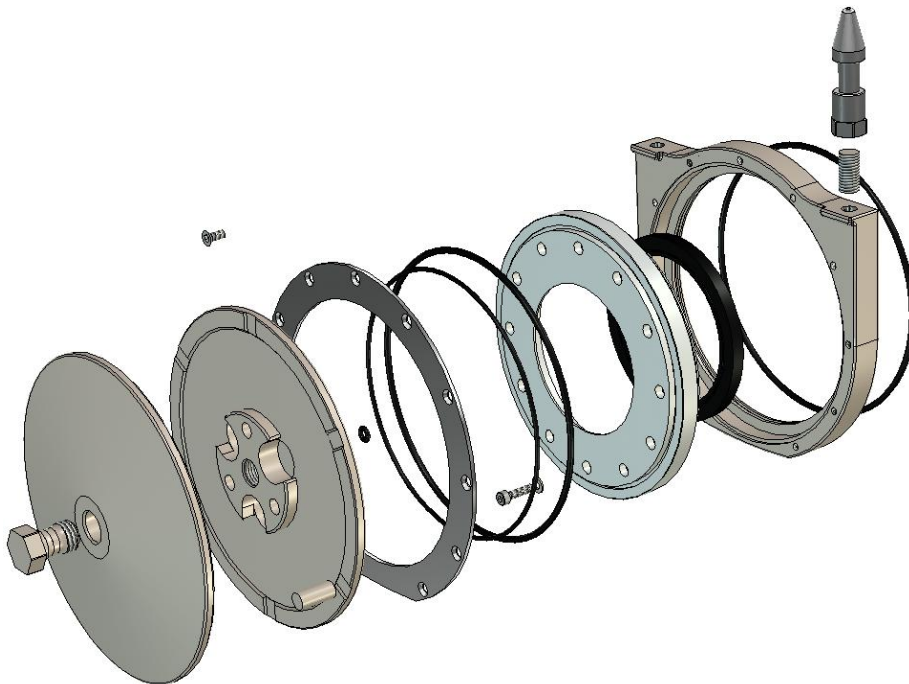

Technical data Pentrunder 6-12HF - HF-wall saw

	Pentrunder 6-12HF
Saw blade diameter max.:	1200 mm (48")
Max cutting depth with 1200 (48") blade:	515 mm (20.3"), Blade radius minus 85 mm (3.35")
Max start blade Ø:	800 mm (32")
Saw blade arbor diameter:	60 mm (1-3/8" for the U.S. market)
Saw blade motor:	15 / 18 kW high frequency motor can be used
Max output power:	15 / 18 kW depending on motor size
Max output torque:	196 Nm (1:st gear, 18 kW)
Spindle speed under load:	1:st gear: 640 - 800 RPM 2:nd gear: 940 - 1200 RPM @350-440Hz
Travel Motor - Max speed:	24V DC – 1.8 m /min
Feed Motor - Max arm rot. Speed:	24V DC – 0.9 rpm
Water feed:	Central through the blade flanges
Standard blade flange:	- 60 mm arbor size, 156 mm outer diameter - 1" arbor size, 6.1" outer diameter - 1-3/8" arbor size, 6.1" outer diameter
Flush cutting flanges:	- 60 mm arbor size, 6x M8 P.C.D. 130 mm - 60 mm arbor size, 6x M10 P.C.D. 110 mm - 60 mm arbor size, 6x M10 P.C.D. 108 mm - 60 mm arbor size, 6x M10 P.C.D. 110 mm & 6x M8 P.C.D. 130 mm - 1-3/8" mm arbor size, 6x 3/8" (M10) P.C.D. 4-1/4" - 1" mm arbor size, 6x 3/8" (M10) P.C.D. 4-1/4"
Weight saw head:	21 kg (46 lbs)
Weight 15 / 18 HF-motor:	13 (28.6 lbs) / 16.5 kg (36 lbs)

Technical details can be subject to change without prior notice.

Technical data Pentpak HF power pack

	Pentpak 418 / 422 / 427	Pentpak 200* / 218 / 222
Input voltage:	380 – 480 V	200 – 230 V
Input frequency:	50 – 60 Hz	50 – 60 Hz
Output frequency:	300 – 500 Hz	300 – 500 Hz
Input power maximum:	31 kW	31 kW
Max. continuous output power (depending on motor size):	15 / 18 / 22 / 27 kW	15 / 18 / 22 / 27 kW
Minimum fuse**:	16 Ampere (25 Ampere for 27 kW)	40 Ampere
Recommended fuse:	40 Ampere	80 Ampere
Current draw at max. output:	56 Ampere (15 – 22 kW)	90 Ampere
Recommended generator size:	45 kVA	45 kVA
Output voltage to feed and travel motors:	24 VDC	24 VDC
Height (incl. handles connectors etc.):	28 cm (11")	28 cm (11")
Width (incl. handles connectors etc.):	30 cm (11.8")	30 cm (11.8")
Length:	68 cm (26.8")	68 cm (26.8")
Weight:	26 kg (57.3 lbs)	26 kg (57.3 lbs)

*400 Hz

** The power output must be reduced to about 65% by turning the feed rate knob to 65%.

Technical details can be subject to change without prior notice.

Declaration of Conformity

We, **Tractive AB** declare that the machine

Manufacturer: Tractive AB
Gjutargatan 54
78170 Borlänge
Sweden

Category: High Frequency Power Pack
Make: Pentpak
Type: 427 / 422 / 418 / 222 / 218 / 200

Is in conformity with the provisions of the Machinery Directive 2006/42/EC.

Is in conformity with the provisions of the following other EC-directives:

- Low Voltage Directive 2006/95/EC
- EMC-Directive 2004/108/EC

In accordance with the EC-declaration of conformity, the product must not be modified without the manufacturer's permission. If this occurs, this documented EC-declaration ceases to apply and the modifier is considered to be the manufacturer and must verify and draw up an addendum to the EC-declaration and file technical data for the inspection authority.

Borlänge 21st of February, 2011



Anders Johnsen

Technical Director

Declaration of conformity

We, **Tractive AB** declare that the machine

Manufacturer: Tractive AB
Gjutargatan 54
78170 Borlänge
Sweden

Category: High Frequency Wall Saw
Make: Pentrunder
Type: 6-12 HF wall saw

Is in conformity with the provisions of the Machinery Directive 2006/42/EC.

Is in conformity with the provisions of the following other EC-directives:

- Low Voltage Directive 2006/95/EC
- EMC-Directive 2004/108/EC

In accordance with the EC-declaration of conformity, the product must not be modified without the manufacturer's permission. If this occurs, this documented EC-declaration ceases to apply and the modifier is considered to be the manufacturer and must verify and draw up an addendum to the EC-declaration and file technical data for the inspection authority.

Borlänge 21st of February, 2011



Anders Johnsen

Technical Director